

VEROTEC

Electronics Packaging

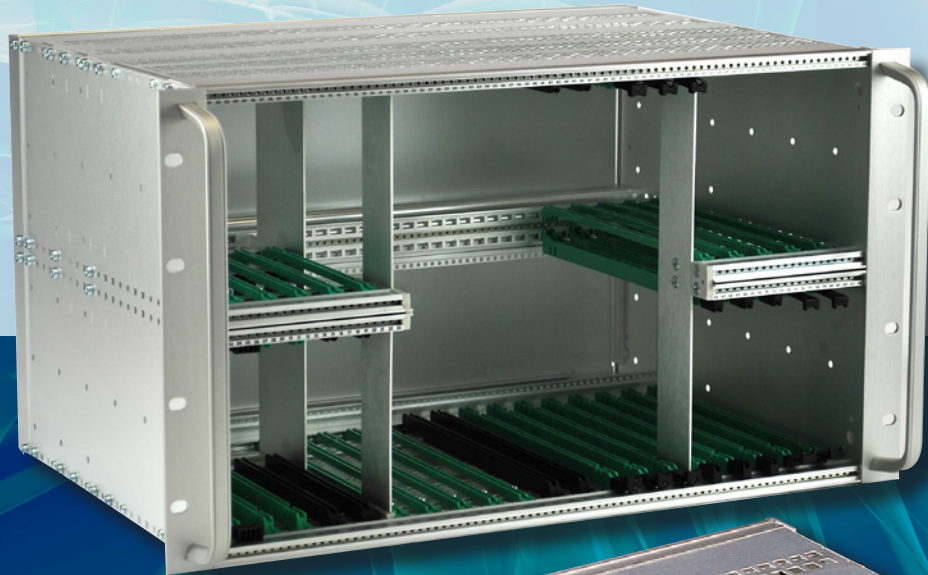

KM6-II Subracks

CUSTOM KM6-II SUBRACKS

TecServ+ is the vehicle by which Verotec delivers its value added services. These fall within 5 main categories and are described below. When it comes to KM6-II subracks, we've worked with many customers in the past to design, manufacture and help bring to market modified and custom versions of our standard products – a small selection of these are pictured below. If you have any special Subrack requirements, please contact our sales office.

ENGINEERING SERVICES:

- ⊕ Complete review of commercial, electro-mechanical, environmental and regulatory product requirements with customer.
- ⊕ Import of STEP, IGES, DWG & DXF file formats
- ⊕ Mechanical and electrical design using latest CAD software
- ⊕ 3D Modelling to allow conceptual testing before production
- ⊕ Component selection from a vast library of parts

MANUFACTURING SERVICES:

- ⊕ Prototype / pre-production samples using small batch shop
- ⊕ Modification of standard catalogue products (including machining, CNC punching, laser cutting, painting & silk-screening)
- ⊕ Manufacture of custom / bespoke products (including fabrication, machining, CNC punching, plating, painting & silk-screening)
- ⊕ Assembly & kitting of components
- ⊕ Integration & mechanical / electrical testing of complex systems

COMPLIANCE SERVICES:

- ⊕ Validation of product design and/or specification
- ⊕ Advice on environment legislation (RoHS, Reach, Weee etc.)
- ⊕ In-house pre-compliance testing for CE marking (Safety, EMC)
- ⊕ Supply of product technical construction file
- ⊕ Testing & certification of a product at an approved test house (for EMC, shock & vibration, altitude, temperature, humidity etc.)

LOGISTICAL SERVICES:

- ⊕ Express manufacturing service for quick turnaround of urgent orders
- ⊕ Special / bespoke packaging for safe transport of goods
- ⊕ Scheduled orders (including JIT and KAN BAN systems)
- ⊕ Stock holding & distribution
- ⊕ Exporting (including export packaging, land/sea/air transportation, freight forwarding, customs documentation & shipping manifests)

PROJECT MANAGEMENT SERVICES:

- ⊕ Initial project consultation
- ⊕ Capability and feasibility study
- ⊕ Estimation of project cost and leadtime
- ⊕ Management of design process (specification to validation)
- ⊕ Management of manufacturing process (prototype to production)
- ⊕ Cost reduction programmes throughout product life cycle



6U, 53HP EMC subrack, split 3U/6U & 160mm/220mm – railway signalling application.

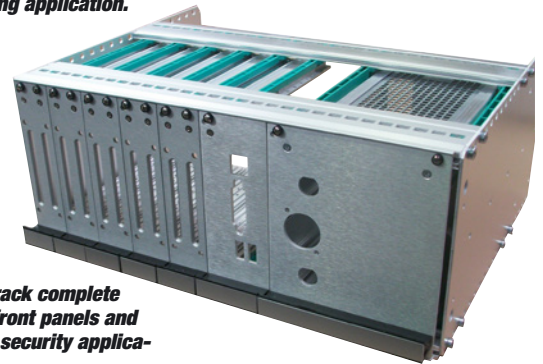

3U, 60HP subrack complete with custom front panels and plug-in unit – security application.



6U, 28HP reversed subrack assembly with VME backplane – military application

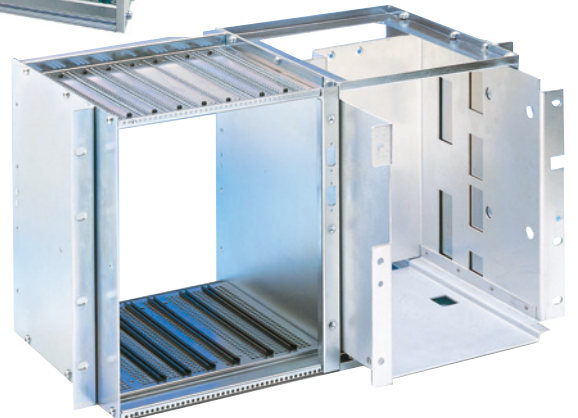

Custom 6U subrack with sheet metal construction and removable peripheral bay – telecoms application.

INTRODUCTION

Fully compatible with DIN 41494 part 5 and IEC 60297-3, KM6-II subracks are strong, versatile and easy to assemble making them well suited to light and medium duty applications. The tiebars are of large section for rigidity and are secured using two fixing screws into counterbored holes. The screws therefore act as locating dowels promoting a high degree of accuracy during construction. The range is extensive, offering 3U, 4U, 6U, 7U and 9U heights in width of 24, 42, 60 & 84HP and depths of 160, 240, 300, 360 & 420mm. KM6-II Subracks are supplied either in kit form or individual component parts and are complimented by a wide range of accessories, including EMC conversion kits, guides, front panels and plug-in modules

Features

- Strong and versatile
- Two screw fixing of tie bars
- Conforms to IEC 60297-3
- Total versatility permits wide range of configurations
- Available in kit or piece-part form
- Accurate location for first time assembly
- Rugged construction
- Pre-tapped holes and machine screws throughout
- EMC conversion (see pages 23 – 27)
- No location mouldings required
- With or without front handles
- Provision for fitting 19" angles front or rear

The 240mm, 300mm, 360mm or 420mm deep endplates, incorporate a series of punched holes so that the tie bars can be assembled at any required position on a 12mm pitch. 300mm and greater depths also have a pattern of additional holes for fixing the chassis system. 84 HP variants are offered in Backplane or DIN 41612 connector mounting and are supplied with or without front handles. DIN 41612 rear tie bars are fully tapped.

Note: 4U and 7U versions can only be ordered from piece parts. Alternative versions of 3U, 6U and 9U subracks can also be ordered from piece parts.

Contents of kits

Description	Qty.	Material/Finish
Side plates	2	2mm or 2.5mm aluminium BS 1470 5251-H24 (NS4 H6) conductive clear chromate
19" rack angles	2	Aluminium alloy BS1474-6063-T6 anodised
Front tie bars	2	Aluminium alloy BS 1474-6063-T6 conductive clear chromate
Rear tie bars	2	Aluminium alloy BS 1474-6063-T6 conductive clear chromate
Center rear tie bar	1(6U) 2 (9U)	Aluminium alloy BS 1474-6063-T6 conductive clear chromate
Tapped strips		
Backplane variants-	4 - 3U	MS zinc passivate
	6 - 6U	MS zinc passivate
	8 - 9U	MS zinc passivate
DIN 41612 variants (the rear extrusions are fully tapped)	2	Aluminium alloy BS 1474 6063T6 conductive clear chromate
All fixings		
Assembly instructions	1	
Optional: handles	2	



KM6-II Subrack with accessories



6U KM6-II Subrack

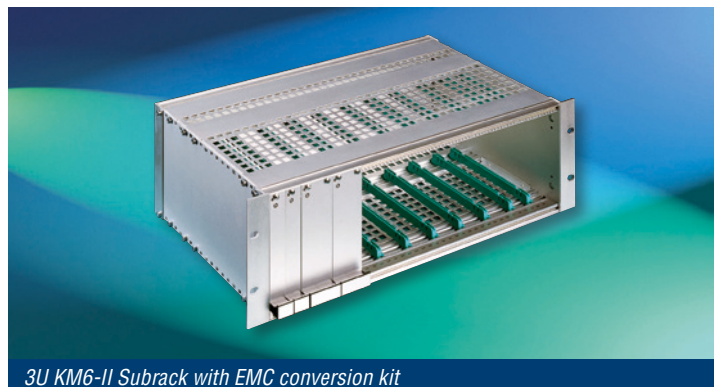

3U KM6-II Subrack with EMC conversion kit

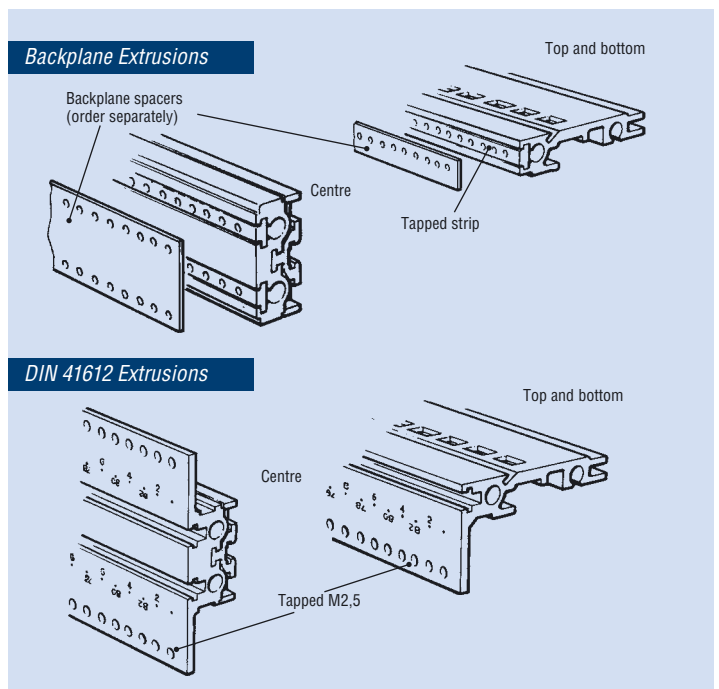

KM6-II SUBRACK, BACKPLANE MOUNTING

Ordering information

Height	Depth (mm)	Width (HP)	Order code without handles	Order code with handles
3U	180	42	950-202583	-
	180	82	950-202581	950-232564
	240	42	950-202592	-
	240	84	950-202589	950-232565
	300	84	950-223550	950-232566
6U	360	84	950-202594	950-232567
	180	42	950-202584	-
	180	84	950-202582	950-232604
	240	42	950-202593	-
	240	84	950-202590	950-232599
9U	300	84	950-223551	950-232601
	360	84	950-202595	950-232602
	420	84	950-202597	950-232603
	240	84	950-202591	-
	300	84	950-224198	-
	360	84	950-202596	-
	420	84	950-202598	-

Notes:

- In order to maintain the correct geometry between the front panels and backplane connectors a suitable backplane spacer is required. Either insulating or conductive types (1mm thick) may be used, and must be located between the rear tie bar and the backplane - refer to page 34.
- Backplane mounting tie bars can be converted to accept DIN 41612 connectors by fitting adaptor kits or rails - refer to page 34.

KM6-II SUBRACK, DIN 41612 CONNECTOR MOUNTING

Ordering information

Height	Depth	Width (HP)	Order code without handles	Order code with handles
3U	240	84	950-232054	950-232570
	360	84	950-232055	950-232571
6U	240	84	950-232056	950-232609
	360	84	950-232057	950-232610

Order separately

Product	Page
EMC Covers/conversion kit	1.19-1.22
EMC Front and Rear Closing Panels	1.22
Backplane spacers	1.29
DIN 41612 connector mounting	1.29
PCB or Plug-in module guides	1.30
PCB Grounding clips & positive retention	1.31
PCB retainers, ejectors and extenders	1.32
Divider Kits	1.33-1.34
Top, bottom and rear dust covers	1.35
Horizontal mounting modules	1.36
Air baffle cards	1.37
Peripheral mounting adaptors	1.37
Subrack handles	1.38
Connector protection kits	1.39
Chassis mounting system	1.40

Note: The conductive finish gives excellent electrical conductivity but is more easily marked than anodising. During assembly care should therefore be taken to avoid the deposition of grease and oil, particularly on the visible surfaces.

3U Subrack

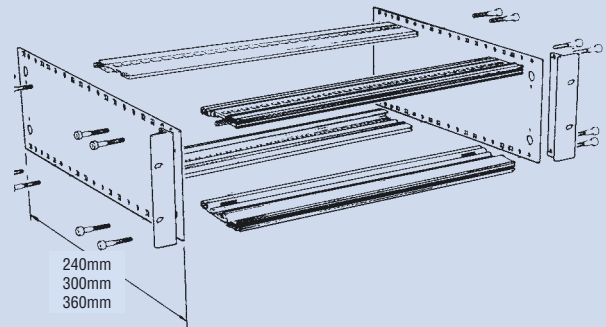

6U Subrack

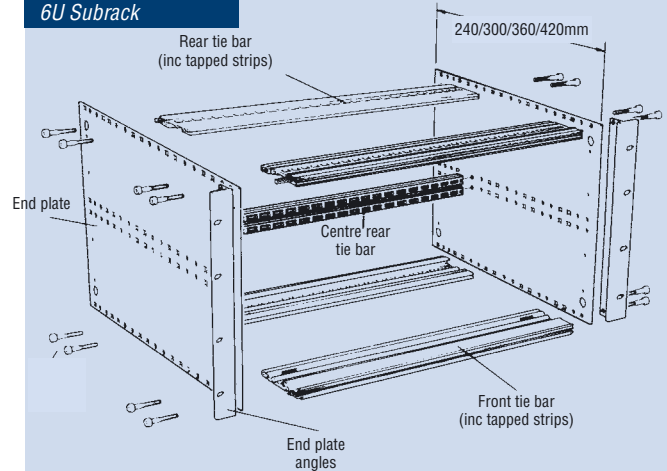

Dimensional Detail

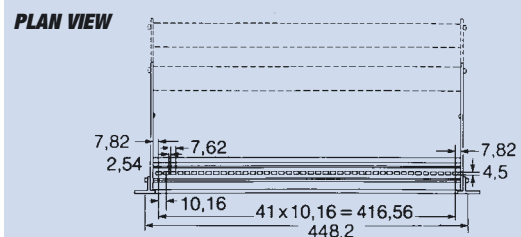
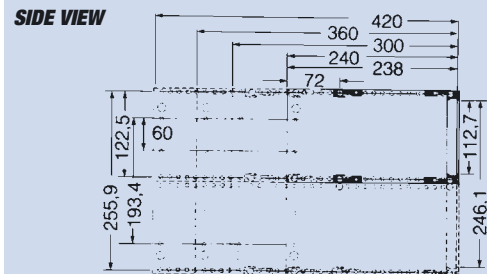
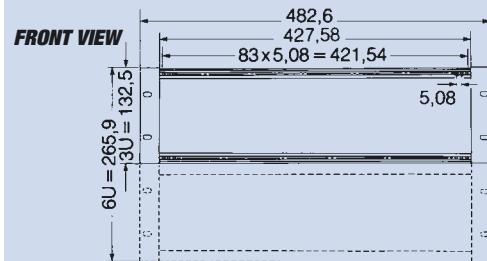

KM6-II EMC CONVERSION KITS

KM6-II subracks can be retrospectively EMC screened or closed by the addition of covers and a suitable front and rear panel.

Two Basic types of screening cover are available:

OVERALL, (Fig. 1) which provide a screen over both the card area and the rear connector/backplane area. In this version, the rear of the subrack is completed by the addition of conventionally fixed panels, either full width or in combinations of lesser width front panels.

PCB AREA ONLY (Fig. 2) This application requires a motherboard/backplane which is specifically designed to provide rear screening using ground plane technology. With this geometry, only the front aperture requires screening panels.

Covers are generally available in ventilated and unventilated forms. They are designed to maintain intimate contact with the end plates by means of screws and internal flanges. At the interface with the extrusions, the covers have patented dimples in such a way as to provide an interference fit with a slot in the extrusion. The concept of this slot ensures that the card guide location holes are within the screened area of the subrack and also provides additional screening by introducing a labyrinth around the edge of the cover.

'A guide to the EMC screening of subracks' on page 12 discusses the effects of various configurations on the overall performance, with particular attention to the use of RFI fingers.

ORDERING AN EMC SCREENED SUBRACK

- 1 Select a Universal subrack kit to suit your card size using table below. Note that, for instance, it is not possible to EMC screen a 220mm long card in a 240 deep subrack.
- 2 Select an EMC conversion kit to suit your subrack and card size (see page 1.20 for Overall Depth Covers and page 1.22 for PCB Depth Covers). Note – for screening 42HP subracks please refer to note 2 on page 1.20
- 3 Select front and rear closing panels as appropriate (see page 1.22).
- 4 Identify total quantity of RFI finger strips required according to the desired performance level of the final assembly. (See page 1.12 for guide and page 1.20 for EMC finger strips).

KM6-II SUBRACKS

PCB Configurations accepted when using EMC conversions and cover kits

Height	PCB Depth (mm)	End Plate (mm)	Order code
3U	160	240	Refer to page 1.18
	160/220	300	
	160/220	360	
6U	160	240	Refer to page 1.18
	160/220	300	
	160/220	360	
9U	160/220/280/340	420	Refer to page 1.18
	160	240	
	160/220	360	
	160/220/280/340	420	



KM6-II EMC conversion kits

Figure 1

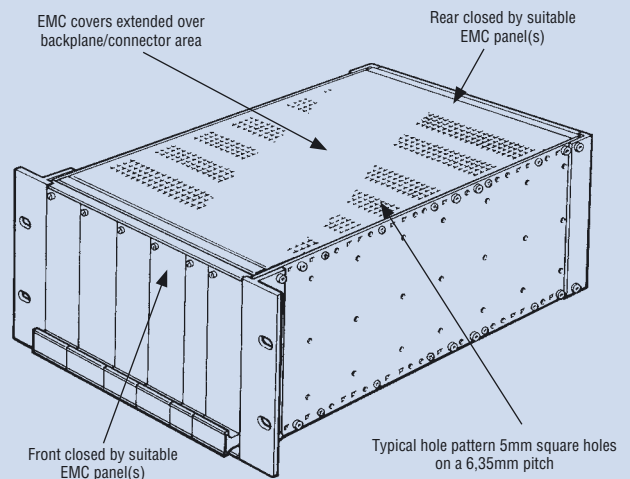
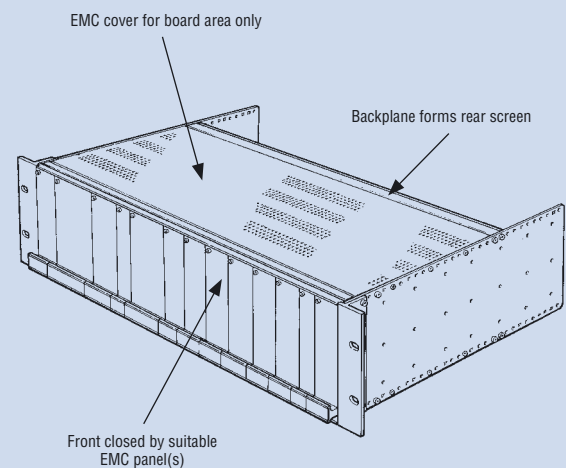

Figure 2



KMG-II Subracks – EMC Conversion / Closing Kit

EMC CONVERSION KITS – OVERALL DEPTH

This kit contains the parts required to convert an 84HP subrack for EMC.

Notes:

1. EMC front and rear panels and EMC fingers should be ordered separately to suit requirements – please refer to page 1.20-1.22.
2. 42HP and 84HP card frames can be effectively screened by ordering the individual covers and rear closing angles featured on pages 1.21, together with the EMC finger strip detailed below.

Contents of kit

Description	Qty.	Material and finish
Plain tie bars	2	Aluminium alloy BS1474-6063-T6 conductive clear chromate
Tapped strips	2	MS Zinc passivate
Rear closing angles	2	Aluminium Alloy BS1474-6063-T6 anodised
Top and bottom covers (either ventilated or unventilated)	2	0,9mm Aluminium alloy conductive clear chromate
All fixings		

KMG-II EMC CONVERSION

Ordering Information

Height	Ventilated	PCB Depth (mm)	End Plate (mm)	Order Code
3U	No	160	240	950-240574
	Yes	160	240	950-240575
6U	No	160	240	950-240576
	Yes	160	240	950-240577
9U	No	160	240	950-240578
	Yes	160	240	950-240579
3U	No	160/220	300	950-240580
	Yes	160/220	300	950-240581
6U	No	160/220	300	950-240582
	Yes	160/220	300	950-240583
3U	No	160/220	360	950-240584
	Yes	160/220	360	950-240585
6U	No	160/220	360	950-240587
	Yes	160/220	360	950-240588
9U	No	160/220	360	950-240589
	Yes	160/220	360	950-240590
6U	No	160/220/280/340	420	950-240562
	Yes	160/220/280/340	420	950-240563
9U	No	160/220/280/340	420	950-240564
	Yes	160/220/280/340	420	950-240565

Figure 3

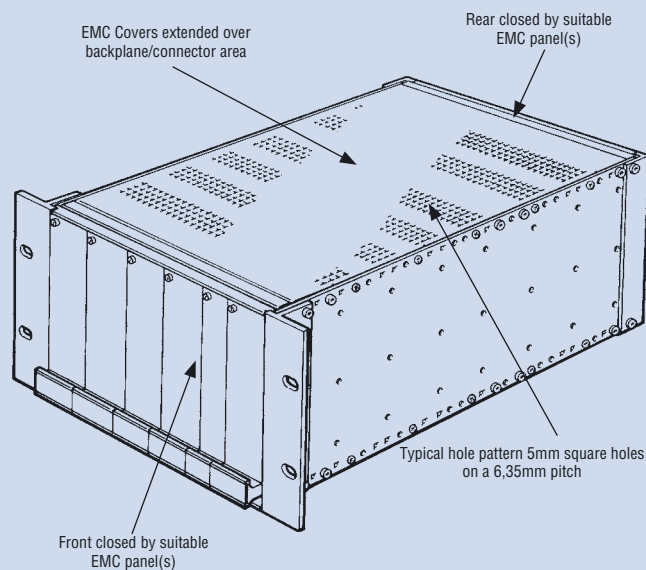

RFI Finger strip

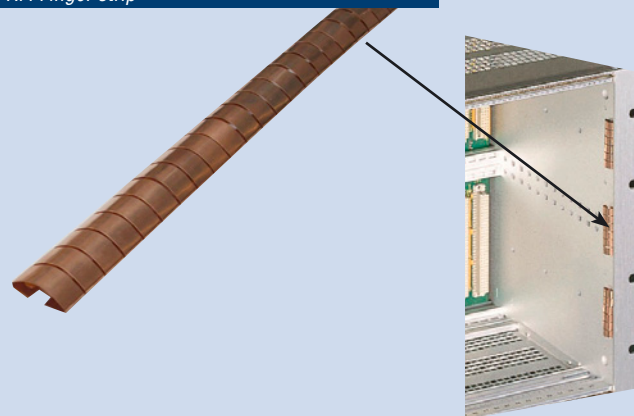

RFI FINGER STRIP

Supplied in lengths of 381mm consisting of 60 fingers. The fingers are self adhesive for easy application and replacement in the field. The quantity of fingers fitted at any panel/subrack interface is selected according to the performance required from the overall screen. Please see page 12 for details. They can be cut using a sharp pair of scissors, taking care to avoid crushing during cutting.

RFI finger strip material: Beryllium copper

Ordering information

Description	Length	Order code
RFI Finger strip	381mm (60 fingers)	930-238243

KM6-II EMC CONVERSION: TOP AND BASE COVERS – OVERALL DEPTH

The 'Overall' EMC conversion kits are also available in their constituent parts. In addition to the 84HP versions, a small range of ventilated overall covers is available in 42HP and 60HP widths. In order to fit these, it is necessary to order reduced width front extrusions and tapped strips, M4 fixing screws and rear closing angles.

Contents of kit

Description	Qty.	Material/Finish
Covers	2	0,9mm aluminium alloy, conductive clear chromate
All fixings		

Ordering Information

Width	Ventilated	PCB Depth (mm)	End Plate (mm)	Order code
42HP	No	160	240	–
	Yes	160	240	950-259417
60HP	No	160	240	–
	Yes	160	240	950-259418
84HP	No	160	240	950-240557
	Yes	160	240	950-240553
42HP	No	160/220	300	–
	Yes	160/220	300	950-259419
	No	160/220	300	950-240556
84HP	Yes	160/220	300	950-240552
	No	160/220	360	950-240559
	Yes	160/220	360	950-240554
	No	160/220	420	950-240558
	Yes	160/220	420	950-240555

REAR CLOSING ANGLES

These are fitted at the rear in conjunction with rear mounting tie bars. EMC Beryllium copper fingers should be ordered separately to maintain the shield between the subrack and EMC panels.

Contents of kit

Description	Qty.	Material/Finish
Angles	2	AL extrusion, conductive clear chromate

Ordering information

Description	Order code
3U Rear closing angles	950-240549
4U Rear closing angles	950-259278
6U Rear closing angles	950-240550
7U Rear closing angles	950-259279
9U Rear closing angles	950-240551

REAR MOUNTING TIE BARS

Two should be ordered per subrack. 84HP version use a plain tie bar. Other widths use standard front tie bars. Sold in singles. Two tapped strips and eight fixings are also required.

Ordering information

Description: Rear mounting bars

Width	Type	Order code
84HP	Plain tie bar	950-221909
	Tapped strip	950-202001
60HP	Front tie bar top	950-202743
	Front tie bar bottom	950-202742
	Tapped strip	950-202740
42HP	Front tie bar top	950-202736
	Front tie bar bottom	950-202735
	Tapped strip	950-202739
Tie bar fixing screws: Pack 100 (4 per tie bar required)		950-202734

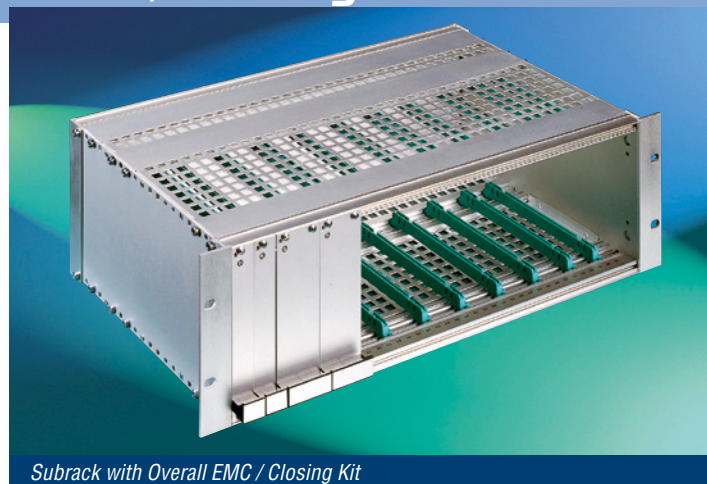

Subrack with Overall EMC / Closing Kit

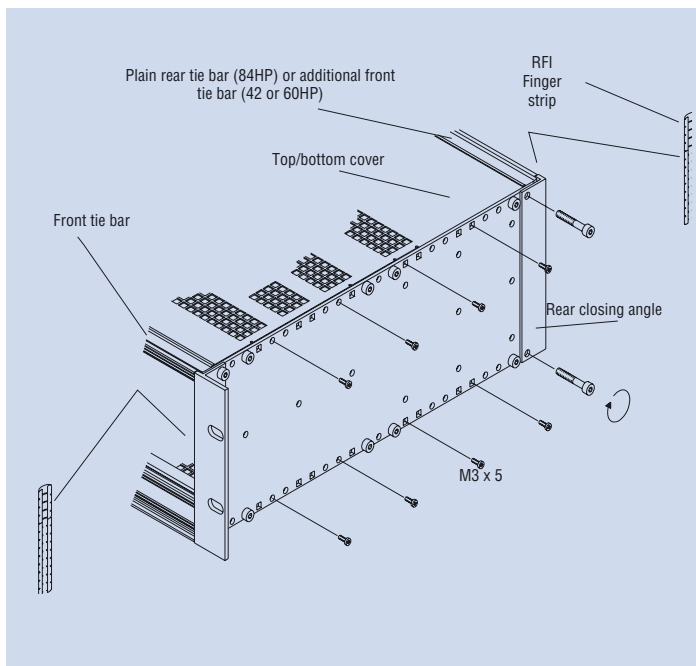

BOARD AREA ONLY EMC COVER KITS

Board area only EMC cover kits (Fig.4) For use in situations where the backplane forms the rear EMC screen, these ventilated covers fit between the front, and backplane, extrusion only.

Select by board depth and subrack width (84HP only); end plate depth is not a consideration.

Contents of kit

Description	Qty.	Materials/Finish
Top and Bottom Covers (ventilated)	2	0,9mm Aluminium alloy conductive clear chromate
Fixings		

Ordering information

Description	Order code
84HP x 160 Ventilated EMC cover	950-259371
84HP x 220 Ventilated EMC cover	950-259372

This performance graph shows the results from randomly selected KM6-II subracks, 6Ux84HPx360 with ventilated and unventilated EMC covers. Both were fitted with overall closing panels and a maximum quantity of BeCu fingers.

Measurements were taken at all six faces and the results shown in the graph are calculated as follows:

H field – minimum figures

E field – minimum figures up to 30MHz above 30MHz the figures for all faces are plotted on a rolling seven point average.

OVERALL CLOSING PANELS

These full width (84HP) closing panels can be used at the front or rear of the subrack and make contact with the end plates and tie bars as described below.

- Type 1** which is secured by twelve captive screws and is available for installations where access is seldom necessary. Contact to the end plates is achieved using beryllium copper fingers.
- Type 2** is secured by four captive screws only, relying on beryllium copper fingers to maintain contact on all four edges.
- Type 3** is a horizontally hinged panel which relies almost entirely on beryllium copper fingers for contact on all four edges, having only two captive screws. A special finger strip is provided with the kit for the bottom flange only.

CONTENTS OF KIT

Description	Finish
Panel inc. fixings	Facia panel etch and clear anodise, inner panel conductive clear chromate
Handles and idents (Type 2 only)	

ORDERING INFORMATION

Description: Overall closing panels

Type	Qty	Width	Height	Order code
1	1	84HP	3U	950-202694
			6U	950-202695
			9U	950-202696
2	1	84HP	3U	951-242957
			6U	951-242958
			9U	951-242959
3	1	84HP	3U	951-242960
			4U	951-259284
			6U	951-242961
			7U	951-259285
			9U	951-242962

Figure 4

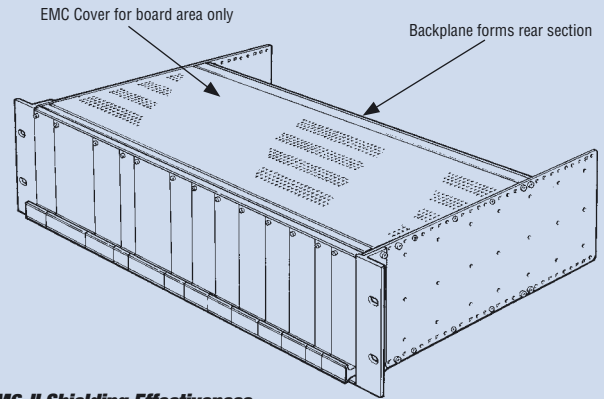

KM6-II Shielding Effectiveness

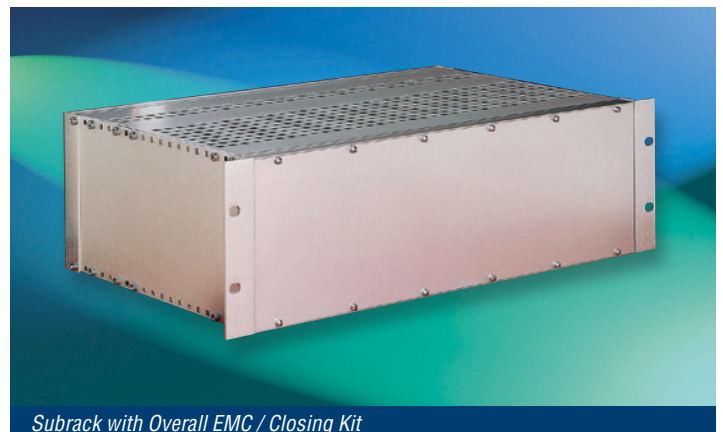
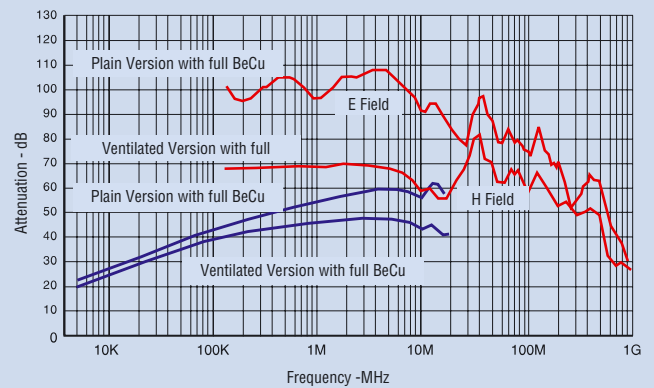

Subrack with Overall EMC / Closing Kit

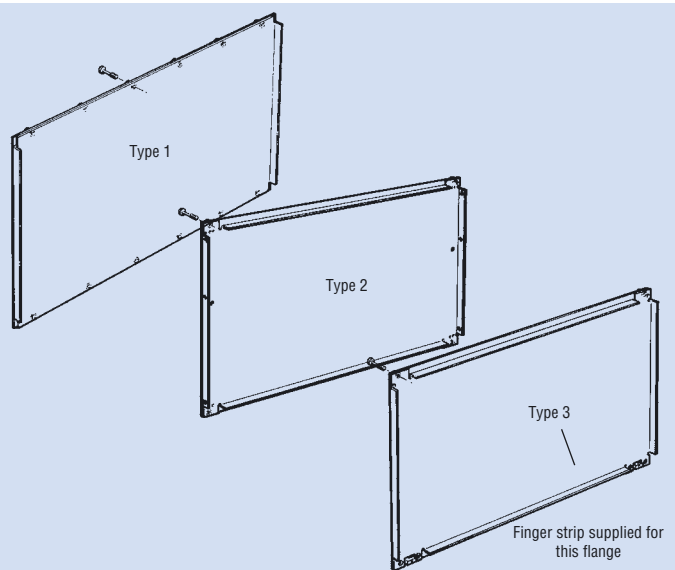

Overall closing panels

KM6-II Subrack kit - Piece parts

KM6-II SUBRACK – PIECE PARTS

KM6-II subrack kits as detailed on pages 1.17 / 1.18 may be ordered by their constituent parts. This allows special configurations to be achieved including 4U and 7U subracks which can only be ordered from piece parts. All subrack kits contain the following parts which are detailed in the following four pages:

Description	Qty	Page
Side Plates	2	1.24
19" Rack Angles	2	1.24
Front Tiebars – Top	1	1.25
Front Tiebars – Bottom	1	1.25
Rear Tiebars - Top & Bottom	2	1.26-1.27
Rear Tiebars – Centre	0 (3U)	1.26-1.27
	1 (6U)	1.26-1.27
	2 (9U)	1.26-1.27
Tapped Strips	4 (3U)	1.27
	6 (6U)	1.27
	8 (9U)	1.27
Assembly Screws	16 (3U)	1.40
	20 (6U)	1.40
	24 (9U)	1.40

Order separately

Product	Page
EMC conversion, covers & closing kits	1.19-1.22
Front & rear EMC closing panels	1.22
Backplane spacers	1.29
DIN 41612 connector mounting	1.29
PCB and PIU guides	1.30
PCB guide earth clips & positive retention	1.31
PCB retainers, ejectors and extenders	1.32
Divider kits	1.33-1.34
Top, bottom and rear dust covers	1.35
Horizontal mounting modules	1.36
Air baffle cards	1.37
Peripheral mounting adaptors	1.37
Subrack handles	1.38
Connector protection kits	1.39
Chassis mounting system	1.40

Note: The conductive finish gives excellent electrical conductivity but is more easily marked than anodising. During assembly care should therefore be taken to avoid the deposition of grease and oil, particularly on the visible surfaces.



KM6-II Subrack Assembly

3U Subrack

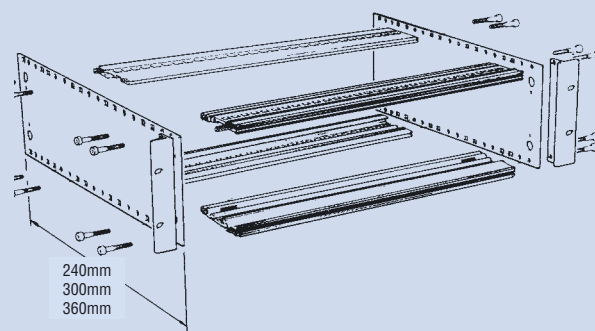

6U Subrack

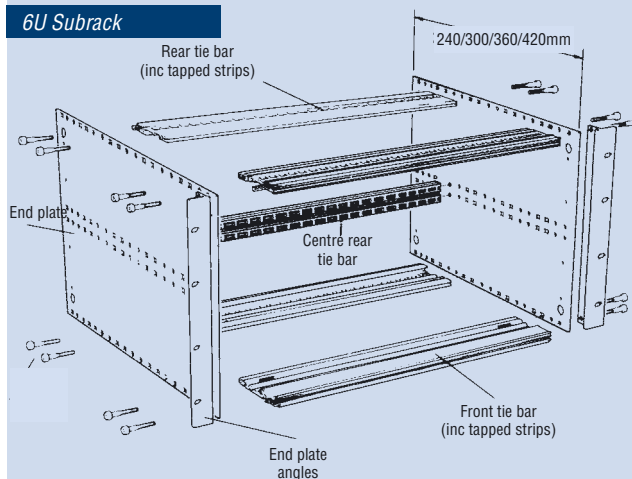

KM6-II Subrack kit - Piece parts

SIDE PLATES

KM6 side plates are punched on a 12mm pitch along their length to enable tie bars to be mounted to suit customer applications.

On 300mm and deeper versions there is also a pattern of intermediate holes to permit the fixing of a chassis or support system.

Identifications are stamped on the side plate to assist in tie bar location. Side plates are sold singly (i.e. 2 required for each subrack).

The 4U x 360 and 7U x 420 versions can be assembled as 3U/6U + 2 x ½U or 3U/6U + 1U.

Ordering information

Description: Side plates

Height	Depth	Thickness	Qty.	Order code
3U	180mm	2mm	1	950-4002866
	240mm	2mm	1	950-202787
	300mm	2mm	1	950-221911
	360mm	2mm	1	950-202790
4U	240mm	2,5mm	1	950-202618
	360mm	2,5mm	1	950-202620
6U	180mm	2mm	1	950-4002820
	240mm	2mm	1	950-202788
	300mm	2,5mm	1	950-221912
	360mm	2,5mm	1	950-202791
7U	360mm	2,5mm	1	950-202793
	420mm	2,5mm	1	950-259286
9U	240mm	2,5mm	1	950-202789
	300mm	2,5mm	1	950-224197
9U	360mm	2,5mm	1	950-202792
	420mm	2,5mm	1	950-202794

Material: 2,0 or 2,5mm Aluminium BS1470 5251-H24 (NS4 H6), conductive clear chromate finish

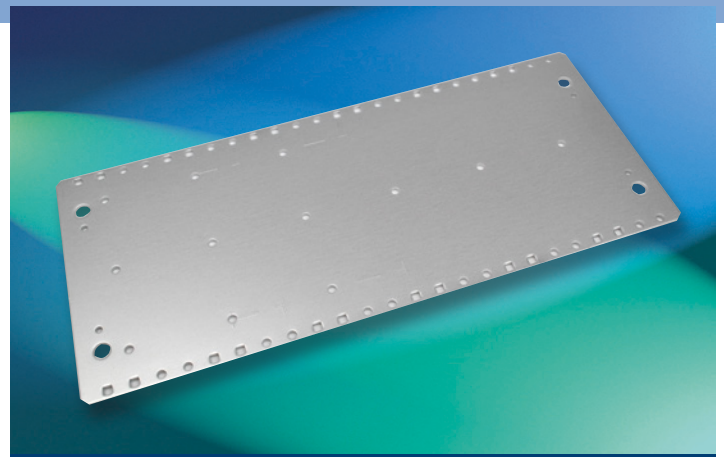

KM6-II Side Plate

END PLATES

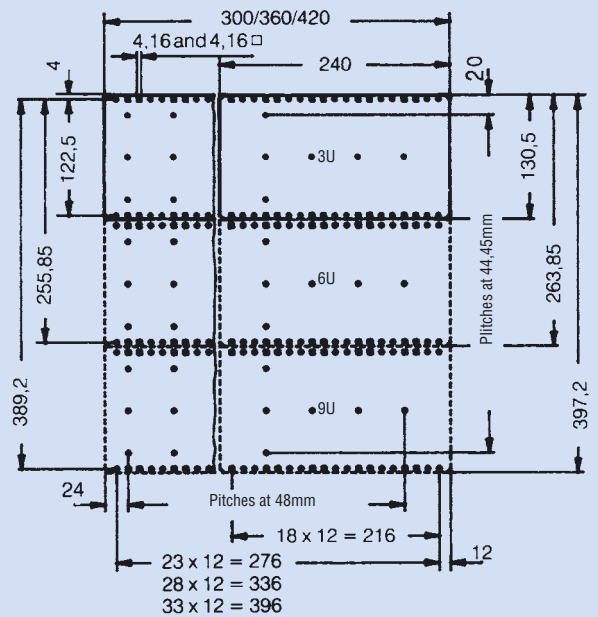

For 4U or 7U dimensions add 44,45 to the 3U or 6U height dimensions. 4U and 7U have a row of holes to suit 3U components.

19" RACK ANGLES

Ordering information

Height	Thickness	Qty.	Order code	
			With handle holes	w/out handle holes
3U	2mm	1	950-232632	950-202783
4U	2,5mm	1	-	950-202616
6U	2mm	1	950-232633	950-202784
	2,5mm	1	950-232635	950-202785
7U	2,5mm	1	-	950-259287
9U	2,5mm	1	-	950-202786

Note: 6U angles vary according to end plate thickness

Material: Aluminium alloy extrusion BS1474-6063-T6, Anodised

19" RACK ANGLE DIMENSIONS

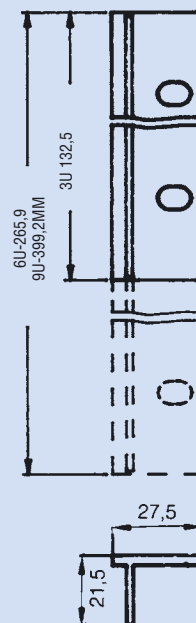

KM6-II 19" Rack angle

KM6-II FRONT TIE BARS

KM6-II front tie bars feature a screw fixing system using a unique dowel-screw arrangement which ensures accurate location and subrack rigidity. An additional slot is provided which, when fitted with a tapped strip, enables pcb and module guides to be secured using M2,5 x 5mm screws, thereby offering greater security and strength (see figure 8).

Provision is also made for the fitting of dust/EMC covers, without the need for additional seals, whilst still maintaining a high level of EMC screening.

Normal front extrusions have slot identification printed along their length to aid guide location. Top versions also have a printed ident on the front face for panel location.

In addition to the normal front extrusion, there are other types:

PLAIN which has no guide location holes; this extrusion is included in EMC conversion kits and can also be used for just attaching additional panels (e.g. for rear socket mounting).

LIPLESS which has normal guide location holes but offers two facilities; if used as a height dividing extrusion, it is possible to use overall front panels (see figure 6); it will also fit within an EMC screen, permitting the recessing of cards (see figure 7).

These extrusions are supplied in lengths of 84HP and can easily be cut to length to suit other width requirements. These tie bars are not silk screen printed.

Contents of kit

Item/Description	Material/Finish
1 tie bar	Aluminium alloy BS 14746063T6 conductive clear chromate

Ordering information

Description	Qty.	Order code
24HP Tie bar - top front	1	950-202796
Tie bar - bottom front	1	950-202795
42HP Tie bar - top front	1	950-202736
Tie bar - bottom front	1	950-202735
60HP Tie bar - top front	1	950-202743
Tie bar - bottom front	1	950-202742
Tie bar - top front	1	950-202644
Tie bar - bottom front	1	950-202643
84HP Plain front tie bar	1	950-221909
Lipless front tie bar	1	950-233073

For tapped strips see Page 1.27

For fixings see Pages 1.40

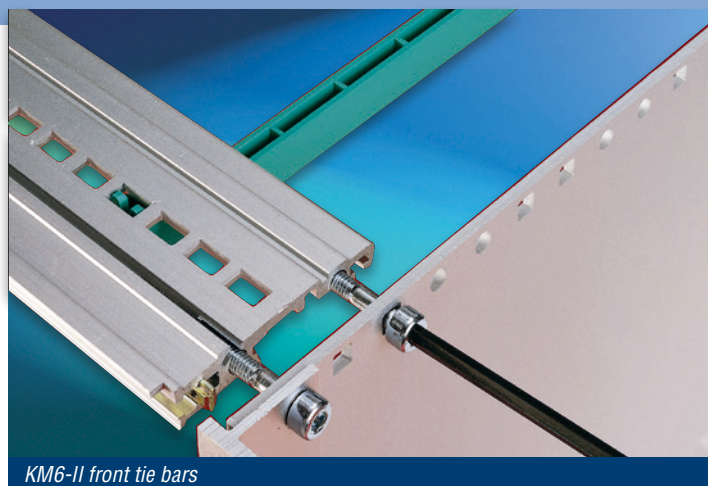

KM6-II front tie bars

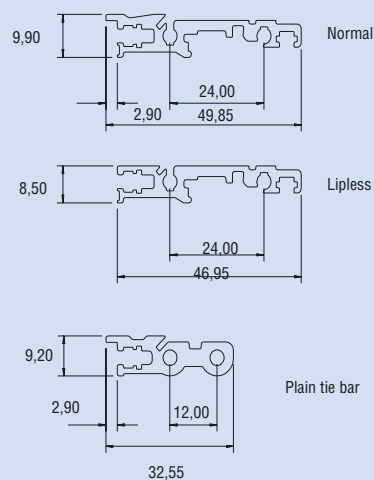

Figure 6

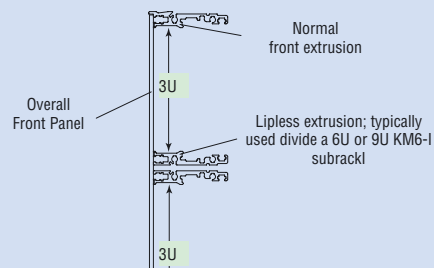

Figure 7

Lipless front extrusion used to recess PCB's in a shielded KM6-II

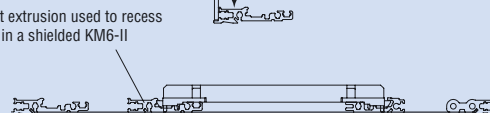
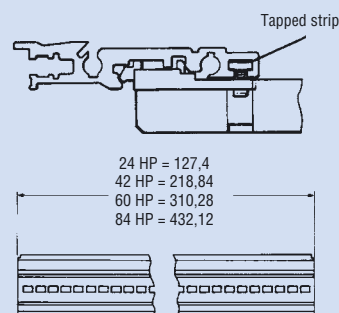

Figure 8

Screw retention of guides in a Universal Subrack



TOP AND BOTTOM REAR TIE BARS – BACKPLANE MOUNTING

KM6-II rear tie bars adopt the same positive screw fixing method as the front ties bars (refer to page 1.25). Once fitted with a tapped strip and the appropriate conductive or insulating spacer (to maintain the correct connector geometry), these tie bars act as supports for the top and bottom of a backplane.

Top and bottom rear tie bars are supplied singly.

Backplane tie bars can be converted to DIN 41612 by means of a connector mounting frame (see page 1.29).

Contents of kit

Description	Qty	Material/Finish
Tie bar	1	Aluminium alloy BS 14746063T6, conductive clear chromate

Ordering information

Rear Tie Bars	Backplane mounting	Qty.	Order code
24HP	Top and bottom	1	950-202797
42HP	Top and bottom	1	950-202737
60HP	Top and bottom	1	950-202744
84HP	Top and bottom	1	950-201276

For tapped strips and DIN 41612 conversion see Page 1,29

For fixings see Pages 1.40

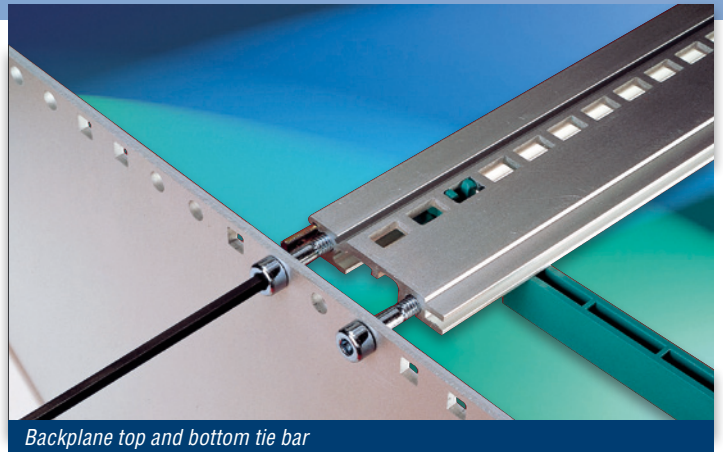

Backplane top and bottom tie bar

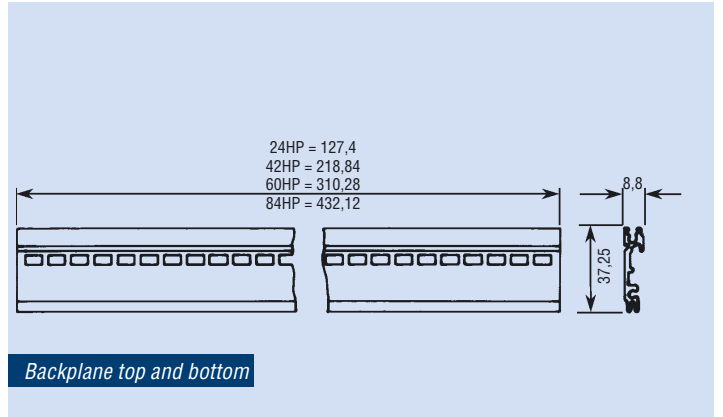

Backplane top and bottom

MID REAR TIE BARS – BACKPLANE MOUNTING

When fitted with tapped strips these tie bars are used as mid-rear backplane mountings. They can also be used to fit a 3U backplane into a 6U, or greater, subrack.

In order to maintain correct connector geometry it is necessary to fit a spacer, either conductive or insulating, between extrusion and motherboard/backplane.

The centre rear tie bar comprises a two-part extrusion kit and a facility is provided for fitting a forward facing tapped strip if required.

Backplane tie bars can be converted to DIN 41612 by means of a connector mounting frame (see page 1.29).

Contents of kit

Description	Qty	Material/Finish
Tie bar	1	Aluminium alloy BS 14746063T6, conductive clear chromate

Ordering information

Description: Rear Tie Bars - backplane mounting			
Width	Location	Qty.	Order code
24HP	Centre	1	950-202798
42HP	Centre	1	950-202738
60HP	Centre	1	950-202745
84HP	Centre	1	950-201277

For tapped strips and DIN 41612 conversion see Page 1.29

For fixings see Pages 1.40

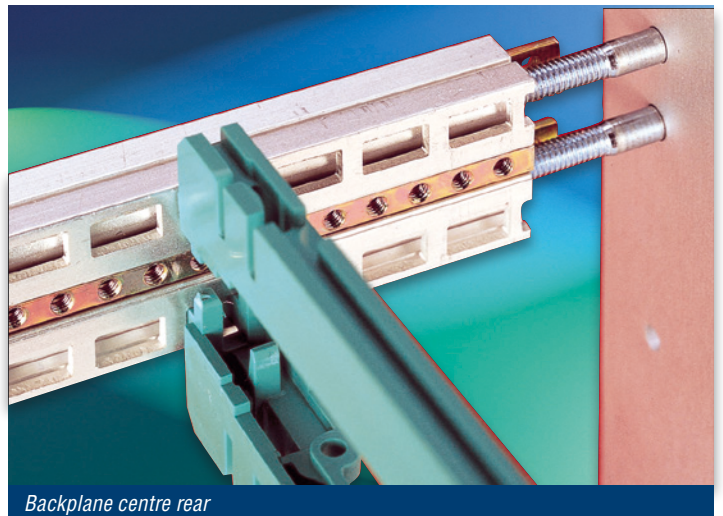

Backplane centre rear

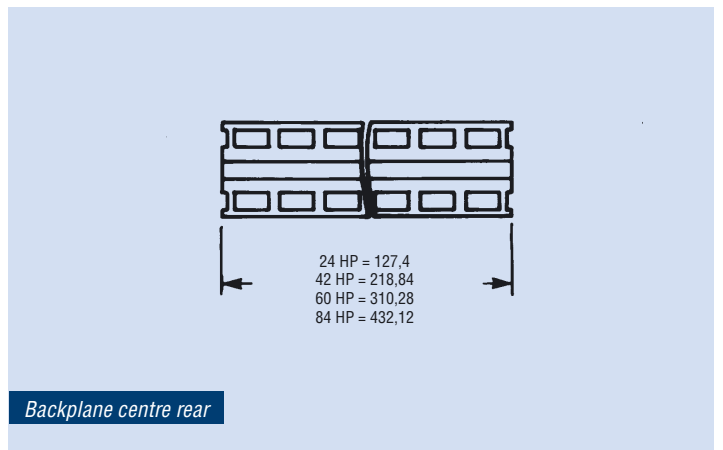

Backplane centre rear

TOP AND BOTTOM REAR TIE BARS – DIN 41612

CONNECTOR MOUNTING

KM6-II Top and bottom DIN 41612 connector mounting tie bars are pre-tapped with M2,5 holes on a 1HP pitch. These tie bars are printed with connector location idents to aid connector assembly, and are not handed.

Contents of kit

Description	Qty	Material/Finish
Tie bar	1	Aluminium alloy BS 14746063T6, conductive clear chromate

Ordering information

Rear Tie Bars	DIN41612 Connector mounting	Qty.	Order code
84HP	Top and bottom	1	950-229781

For fixings see Pages 1.40

MID REAR TIE BARS – DIN 41612 CONNECTOR MOUNTING

For DIN 41612 connector mounting the tie bar is pre-tapped M2.5 on a 1HP pitch. These tie bars are printed with connector location idents, but are not handed.

Contents of kit

Description	Qty	Material/Finish
Tie bar	1	Aluminium alloy BS 14746063T6, conductive clear chromate

Ordering information

Description: Rear Tie Bars - DIN 41612 connector mounting			
Width	Location	Qty.	Order code
84HP	Top and bottom	1	950-229784

For fixings see Pages 1.40

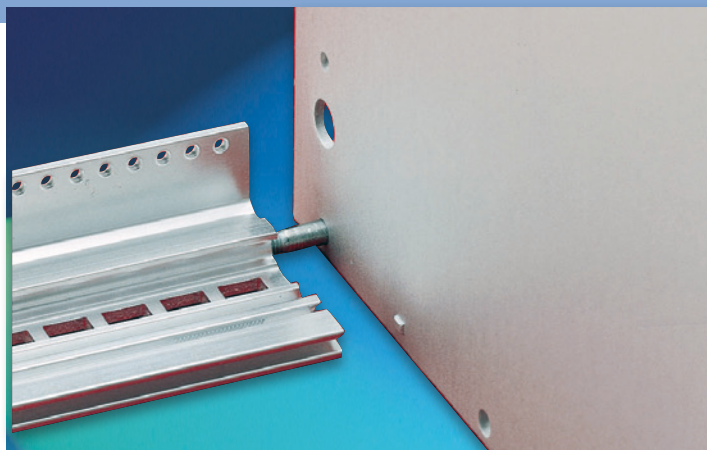

DIN 41612 top and bottom tie bar

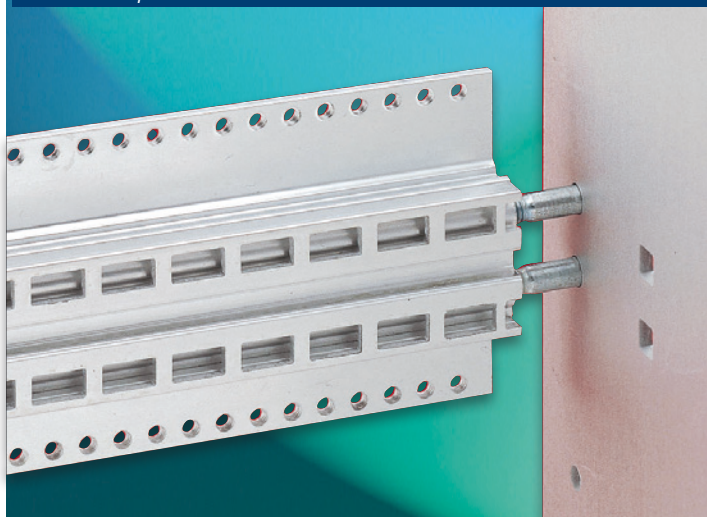

DIN 41612 centre rear

TAPPED STRIPS

Tapped M2,5 holes on a pitch of 1HP, these strips are used for fixing front panels, backplanes, or as an option for chassis plates. As an alternative to tapped strips, a slide nut suitable for use in front tie bars only can be used where a small number of locations are required.

Contents of kit

Description	Qty	Material/Finish
Tapped strip	1	Mild steel zinc and colour passivate

Ordering information

Description	Qty.	Order code
24HP Tapped strip	1	950-202799
42HP Tapped strip	1	950-202739
60HP Tapped strip	1	950-202740
84HP Tapped strip	1	950-202001
Slide nut	10	124-30499



Tapped strip

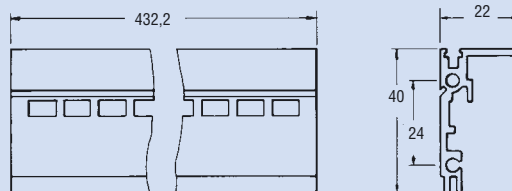

DIN 41612 top and bottom

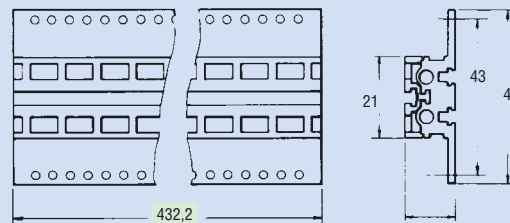

DIN 41612 centre rear

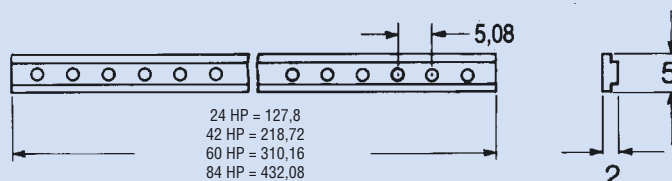

ACCESSORIES

A wide range of accessories is available – from a simple tapped strip for fixing front panels, through DIN connector mounting systems and divider kits to fixings for mounting backplanes – enabling you to tailor the KM6-II subrack system to the exact requirements of your project.

ACCESSORIES INDEX

Tapped strips	1.29
DIN 41612 connector mounting frame	1.29
DIN 41612 connector mounting extrusion	1.29
Backplane spacer strips	1.29
Single guides	1.30
Three part guides	1.30
PCB Grounding clip	1.31
Positive guide retention	1.31
PCB Retainers	1.32
PCB Guide nose	1.32
PCB Injector/ejector	1.32
Front divider kits	1.33
Rear divider kits	1.34
Top and base covers – non-EMC	1.35
Rear cover kit	1.35
Horizontal mounting modules	1.36
Peripheral mounting adaptors	1.37
Air baffle cards	1.37
Subrack Handles	1.38
Rear hinged connector mounting panel	1.39
Rear Framing kit	1.39
Connector protection plates	1.39
Chassis system extrusions	1.40
Subrack fixings	1.40

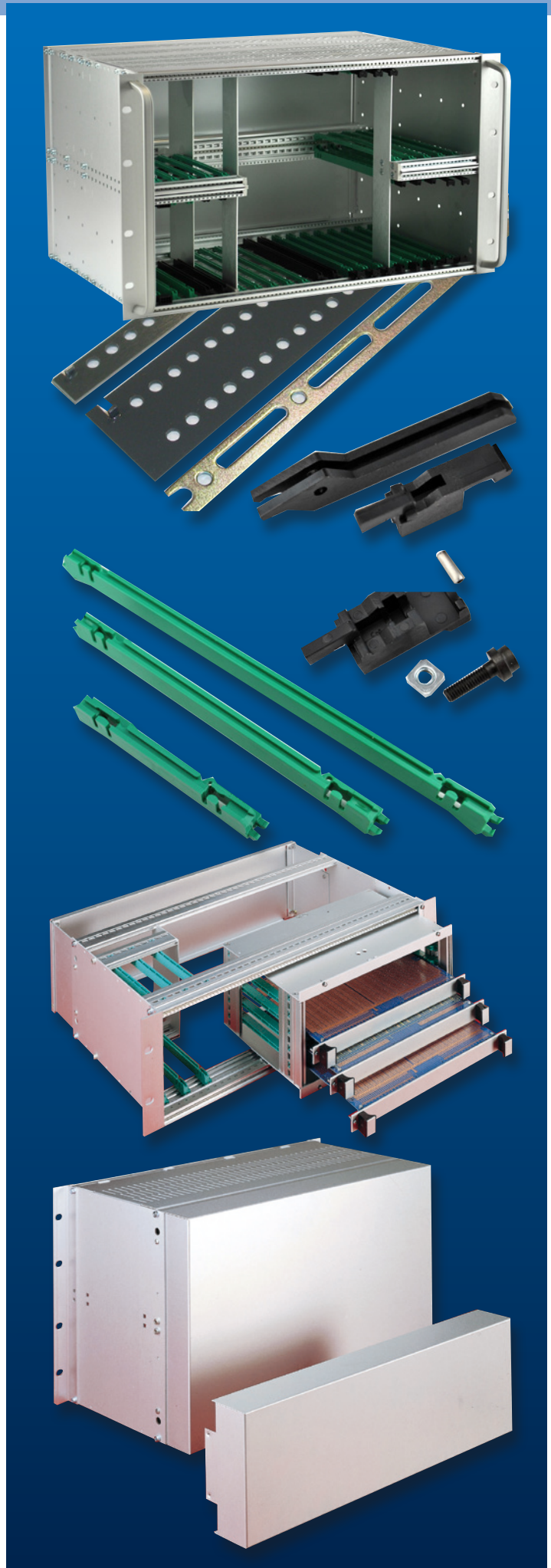

TAPPED STRIPS

Tapped M2,5 holes on a pitch of 1HP, these strips are used for fixing front panels, backplanes, or as an option for chassis plates. As an alternative to tapped strips, a slide nut suitable for use in front tie bars only can be used where a small number of locations are required. Also available is an M3 tapped strip for such applications as ATCA backplane mounting.

Contents of kit

Description	Qty	Material/Finish
Tapped strip	1	Mild steel zinc and colour passivate

Ordering information

Description	Qty.	Order code
24HP Tapped strip	1	950-202799
42HP Tapped strip	1	950-202739
60HP Tapped strip	1	950-202740
84HP Tapped strip	1	950-202001
84HP M3 Tapped strip	1	950-276330
Slide nut	10	124-30499

DIN 41612 CONNECTOR MOUNTING FRAME

- Converts backplane extrusions to DIN 41612 mounting
- Separate assembly and wiring possible
- 3U height
- Various widths
- Conductive finish

This frame is supplied as a kit comprising 2 aluminium extrusions with M2,5 holes on a 1HP pitch, two steel end plates and fixings.

Ordering information

Description	Qty.	Order code
24HP DIN 41612 connector mounting frame	1	950-34247
42HP DIN 41612 connector mounting frame	1	950-34246
84HP DIN 41612 connector mounting frame	1	950-34244

DIN 41612 CONNECTOR MOUNTING EXTRUSIONS

As an alternative to the mounting frame the horizontal extrusions are available in separate kits. A 6HP version is of particular use for mounting one connector to mate with a power supply plug-in units. There is also a version at 84HP width. In both cases, the kit comprises two extrusions and fixings.

Ordering information

Description	Qty.	Order code
6HP horizontal extrusions separate kits	2	950-249491
84HP horizontal extrusions separate kits	2	950-249489

BACKPLANE SPACER STRIPS

Two types of spacer strips are available, insulating and conductive. The insulating type is available in one and two level versions, each having half shears to aid assembly. The two-level version is used on centre rear tie bars. The 84HP strips can be easily cut down for smaller widths.

The conductive strip is 42HP wide and supplied singly.

Note: If conductive spacer strips are used in 84HP subracks please order 2 x 42HP spacer strips per tie bar.

Contents of kit

Item/Description	Material/Finish
Insulating spacer	1mm insulating/grey PVC UL94V0
Conductive	1mm MS zinc and passivate

Ordering information

Description	Qty.	Order code
Insulating spacer single level	1	950-10014
Insulating spacer two level	1	950-10015
Conductive spacer 42HP only	1	173-60788

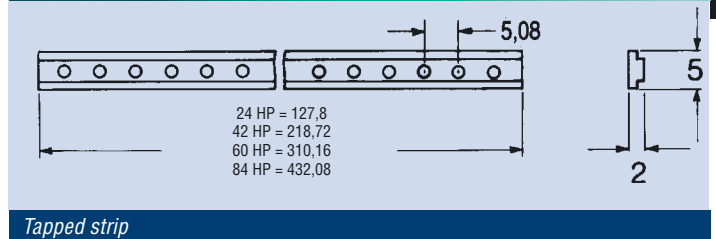
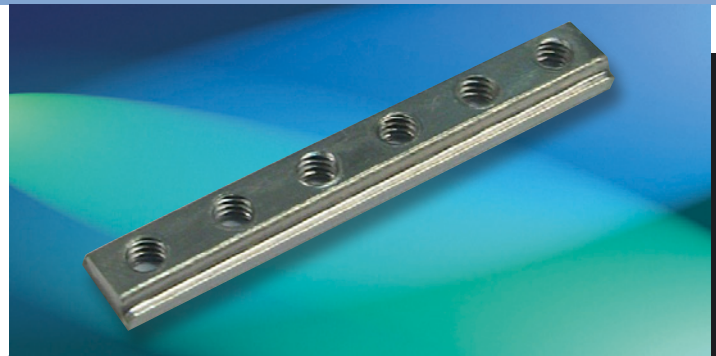

Tapped strip



DIN 41612 connector mounting frame

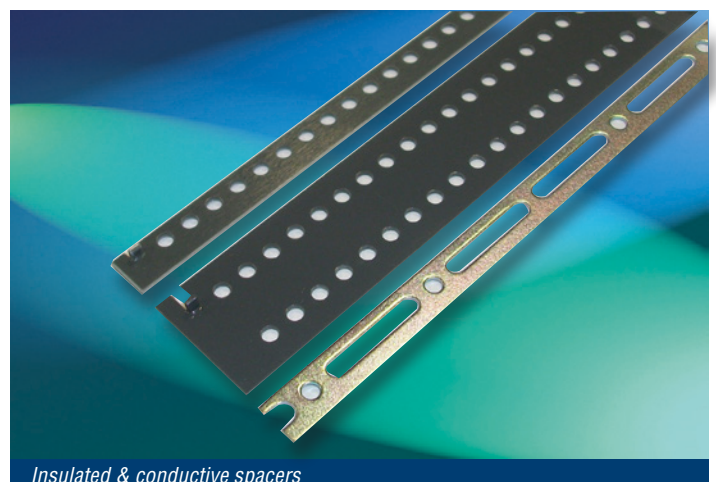

Insulated & conductive spacers

KM6-II GUIDES

A number of different guides are available to suit both standard eurocards and also 111.76/245.1mm high (3U/6U) plug-in units, in a variety of depths and card thicknesses.

SINGLE PART GUIDES

- Type 1 PCB** For Eurocards of 1,6mm thickness, either 100mm, 160mm or 220mm long. Compatible with grounding clip & bolt-down screw.
- Type 2 PCB** For Eurocards of 2,4mm thickness, either 160mm or 220mm long. Not compatible with grounding clip or bolt-down screw.
- Type 3 PIU** For standard plug-in units (111.76 or 245.1mm height), 1,6mm thickness, 160mm or 220mm long. Not compatible with grounding clip, compatible with bolt down screw.
- Type 4 PCB** For Eurocards of 1,6mm thickness, 220mm long, this guide will fit over intermediate extrusions, permitting mixing of pcb depths. Compatible with grounding clip & bolt-down screw.

Contents of kit

Description	Material/Finish
Type 1,3 & 4	Luranylo 2452/1 or equivalent, green
Type 2	Luranylo 2452/1 or equivalent, black

Ordering information

Description: KM6-II Guides - One part

Type	Application	Board Length	Qty.	Order code
1	PCB 1,6mm thick	100 mm	10	950-242850
		160 mm	10	950-232662
		220 mm	10	950-232663
2	PCB 2,4mm thick	160 mm	10	173-232666
		220 mm	10	173-232667
3	Plug-in-unit	160 mm	10	950-232664
		220 mm	10	950-232665
4	Low profile PCB	220 mm	10	950-232668

THREE PART GUIDES

For Eurocard PCB or PIU depths of 280mm, 340mm & 400mm, the below three part guides should be used. Comprising a centre aluminium section (with plastic insert) and two guide feet, they can easily be cut to suit other custom lengths. (Note that the centre extrusion should be cut 76mm short of the desired eurocard length, e.g. a 400mm guide would have a 324mm long extrusion)

Contents of kit

Item/Description	Material/Finish
Centre extrusion	Al extrusion, anodised, plastic side-in section Noryl 2452/1 α , black
Guide feet	Noryl 2452/1 α , green

Luranylo 2452/1 is a UL94 VI rated material with a continuous rating of 105°C

Ordering information

Description: KM6-II Guides - Three part

Type	Application	Board Length	Qty.	Order code
5	PCB 1,6mm thick	280 mm	10	950-276108
		340 mm	10	950-276109
		400 mm	10	950-276110
6	Guide feet, PCB 1,6mm thick		10 prs.	950-202635
8	Guide feet, PIU 1,6mm thick		10 prs.	950-202636



Single part guides

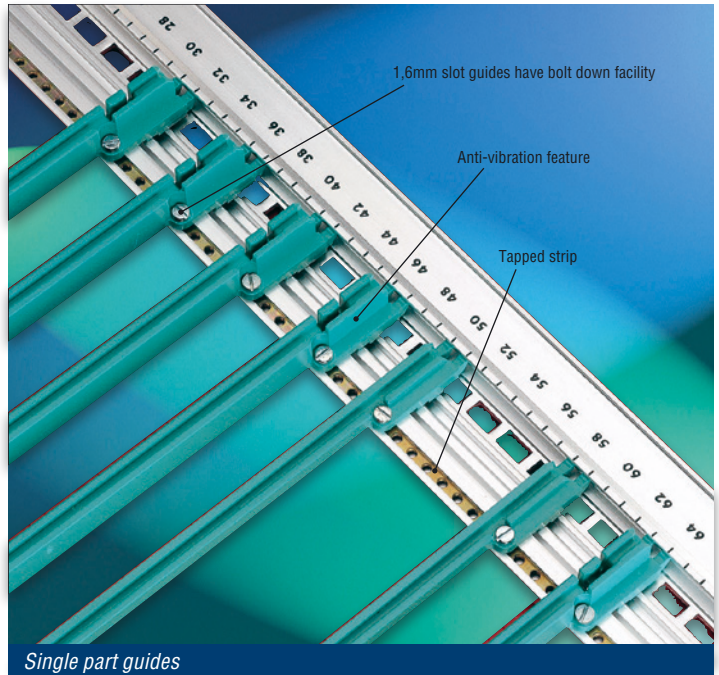

Single part guides

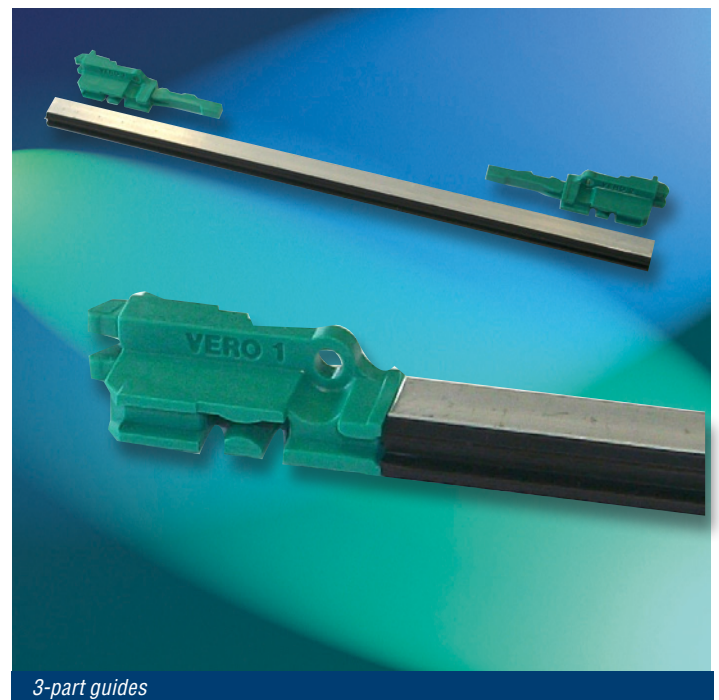

3-part guides

PCB GROUNDING CLIP

This grounding clip can be inserted into the front or rear of 1,6mm pcb guides in KM6 subracks.

Features

- Electrostatic Protection
- Occupies 'unused' area of Eurocard
- No screws required

Contacts on the clip provide electrical continuity between a suitably equipped Eurocard and, via a spring under the clip to standard front extrusions. Pcb's can, therefore, be grounded before the engagement of connectors. The clip, which is supplied in packs of 10, fits into a 'pocket' in the guide and requires no screw fixings to maintain contact.

The modification required to the pcb takes the form of a conductive strip along the edge of the board, either on the left or right side (see illustration). The clip has been tested to IEC 950: 1986 section 2.5.11. In testing, the clip reached a steady temperature of 76 degrees C at 15A, with a resistance path of 7mΩ. A typical electrostatic discharge would be 12A for a period of 1 microsecond.

It should be noted that the clip is designed to provide a ground path for electrostatic charges, not for a power short circuit or as a ground rail.

Contents of kit

Description	Material/Finish
Grounding clip	0,15mm spring steel plated

Ordering information

Description	Qty.	Order code
Grounding clip	pk 10	950-251366

POSITIVE GUIDE RETENTION – TAPPED STRIPS

All KM6-II guides, with the exception of the 2,4mm slot version, can be bolted down to a tapped strip in the front extrusion to give shock and vibration resistance.

Tapped strips (supplied singly) should be selected by subrack width.

The screw used is M2,5 x 5mm cheesehead, supplied in a packet of 100.

Ordering information

Description: Positive guide retention			
Type	Width	Qty.	Order code
Tapped Strip	24HP	1	950-202799
	42HP	1	950-202739
	60HP	1	950-202740
	84HP	1	950-202001
Security fixing screws	M2,5 x 5	100	173-202579

Note: for other widths and for divider kits, a longer strip should be cutdown to suit.

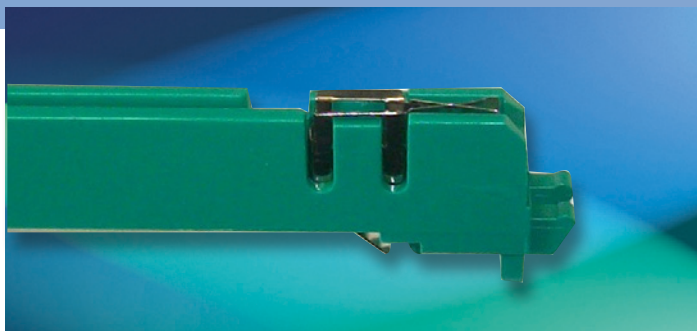

PCB Grounding clip

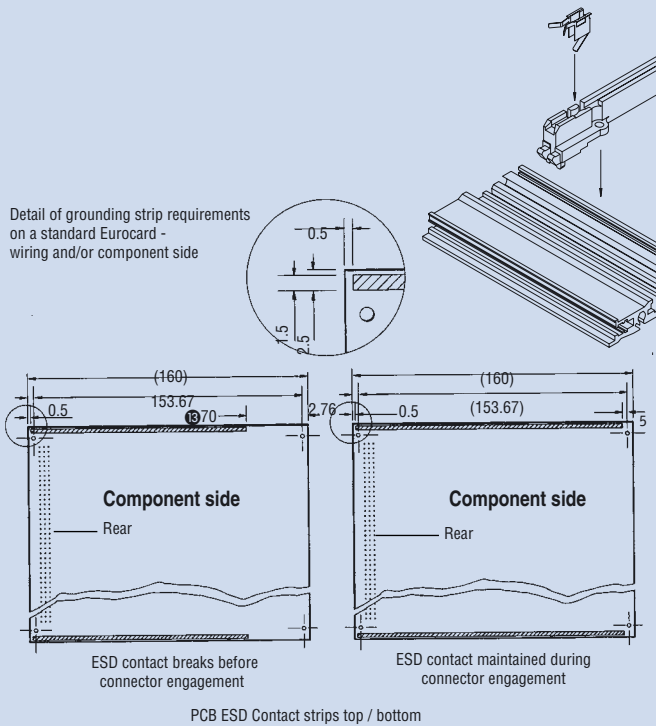

Positive guide retention – tapped strips

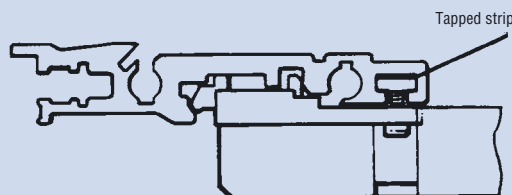

Screw retention of guides in a KM6-II subrack

PCB RETAINERS

Card retainers are available in two types, normal and security. The normal retainer is positioned directly in front of the guide moulding and is operated by finger pressure as illustrated to release the PCB. The security retainer is designed for extra security in vibrative environments and is operated by a unique screw arrangement.

Once clipped in position in front of a PCB guide, complete security is achieved by 3 turns anti-clockwise of the retaining screw with a screw driver.

Contents of kit

Description	Qty.	Material/Finish
PCB retainer	pk. 10	Noryl (GFN/701 code 1V) black

Ordering information

Description: PCB Retainers

Retainer	Order code
Type	
Normal	173-13821
Security	173-24768

PCB INJECTOR/EJECTOR

PCBs fitted with multiple DIN connectors can require very high insertion and withdrawal forces. These injector/ejectors comprise levers which fit to the PCB and saddles which are retained in front of the guide.

It is recommended that guides are screwed down where insertion forces are excessive. See page 1.38.

Contents of kit

Description	Qty.	Material/Finish
PCB injector/ejector	pk 10 pairs	Glass filled nylon 66
Fixings		

Ordering information

Description	Qty.	Order code
PCB injector/ejector	10 pairs	950-251174

PCB GUIDE NOSE

- Assists location of PCBs
- Extends existing KM6 PCB guide

The guide nose fits to standard 1,6 PCB guides, extending their length to within 5mm of the inside face of a front panel. The increased length is especially useful for locating circuit boards in subracks which are above or below eye level. It also provides a purchase point for the operation of certain types of card ejector.

Contents of kit

Description	Qty.	Material/Finish
PCB guide nose	pk 10 pairs	Noryl SE1, black

Ordering information

Description	Qty.	Order code
PCB guide nose	10 prs.	173-232679

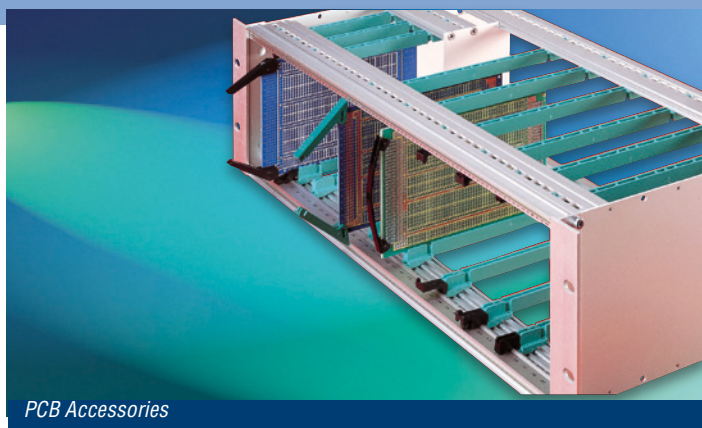

PCB Accessories

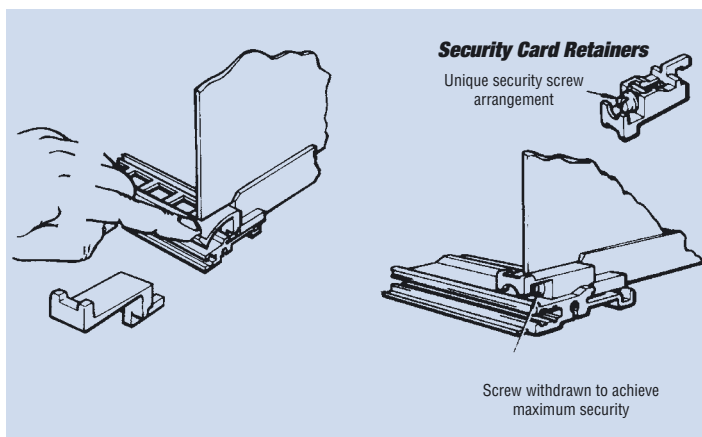

PCB Retainers

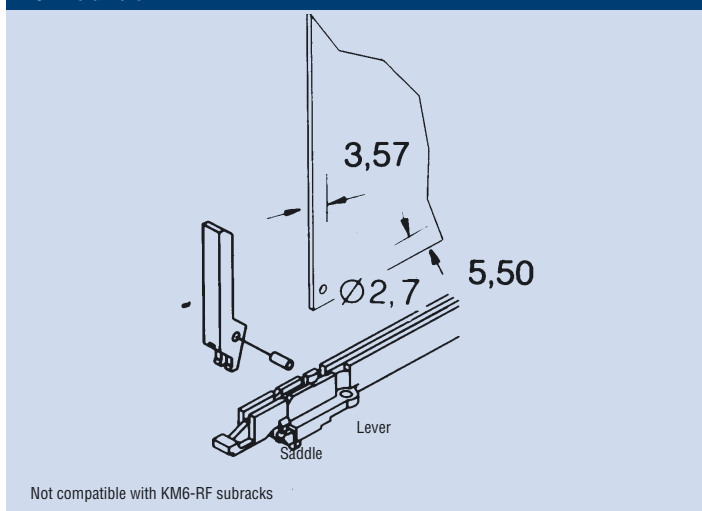

PCB Injector/Ejector

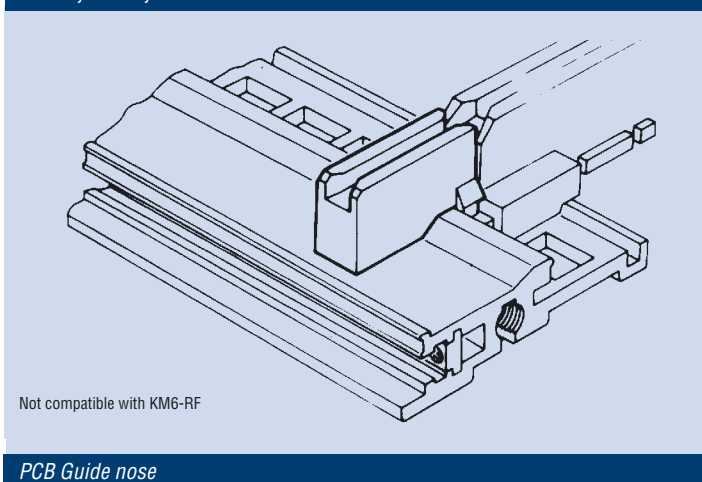

PCB Guide nose

KM6-II 6U FRONT DIVIDER KITS

KM6-II, front divider kits can be fitted after assembly of the subracks.

For use with 6U subracks, these divider kits provide a useful way to mix 3U and 6U board heights within a unit. The divider section is available in different widths, from 21HP to 84HP, and divides the subrack from either the left hand or right hand side.

The design of the kit is such that there is no loss of front panel space. It should be noted, however, that the divider plate restricts the use of 'C' type connectors to plug-in units of 4 HP width, or greater, at the position immediately to the left of the plate.

Contents of kit

Description	Qty.	Material/Finish
Front extrusions	2	Aluminium alloy BS 1474HE9TF conductive clear chromate
6U divider plate (not 84HP version)	1	1,6mm aluminium alloy BS1470NS4 1/2H conductive clear chromate
Location mouldings (not 84 HP version)	3	Luranyl 2452/1α
Tapped strips	2	Steel, zinc plated and colour passivated
Fixing screws		

KM6-II 9U FRONT DIVIDER PLATE

This plate will divide a 9U subrack into 3U and 6U sections. It should be ordered in conjunction with 6U front divider kits. (The 6U plate is discarded.)

Ordering information

Description	Order code
9U divider plate	950-202622

= Denotes minimum order quantity, please contact our sales office

KM6-II LEFT HAND AND RIGHT HAND DIVIDER KIT

Ordering information

Description: Left hand divider kit			
Height	Division	Width	Order code
6U	Left hand divider kit	21HP	950-202604
		24HP	950-202605
		42HP	950-202606
		60HP	950-202607
Full width divider kit 84HP			950-201275
Description: Right hand divider kit			
6U	Right hand divider kit	21HP	950-202609
		24HP	950-202610
		36HP	950-202615
		42HP	950-202611
		60HP	950-202612
Full width divider kit 84HP			950-201275

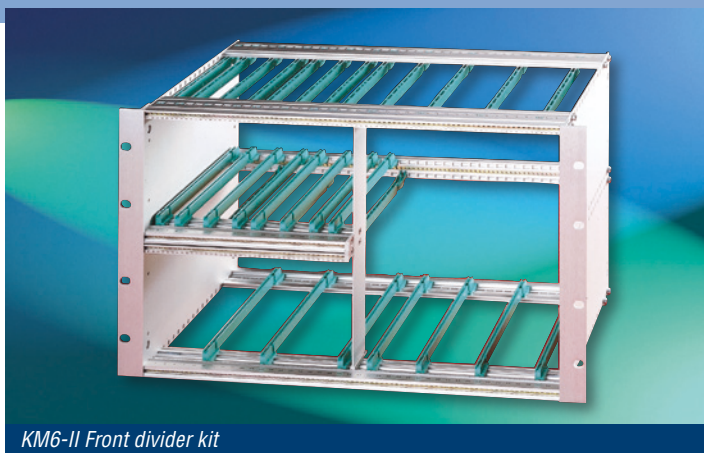

KM6-II Front divider kit

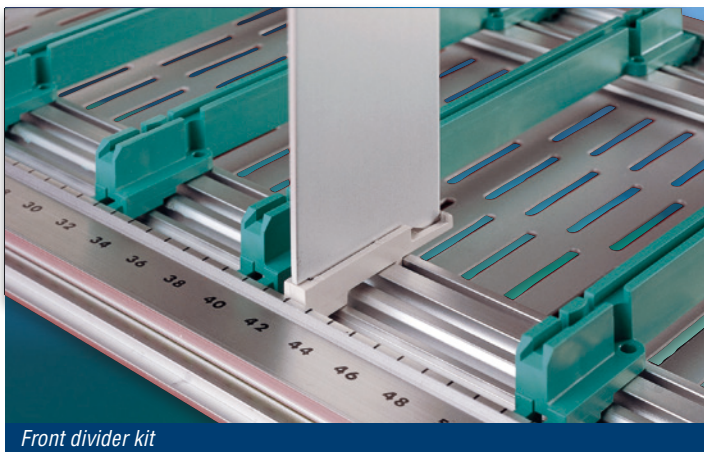

Front divider kit



Front divider plate

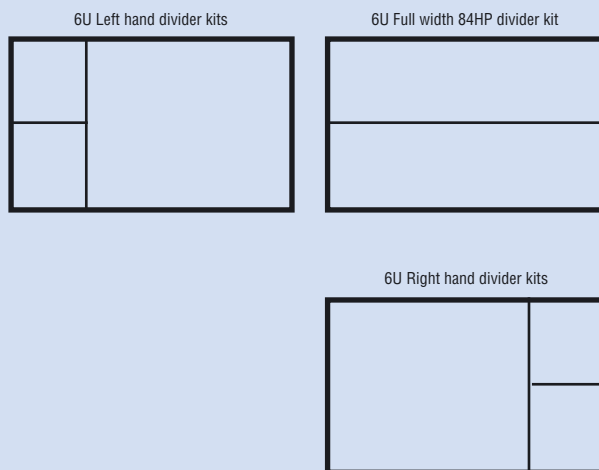

REAR DIVIDER KITS

Rear dividers shorten the depth of the subrack by 60mm locally at the rear, and are employed when it is necessary to use mixed depth PCBs or modules within a 3U or 6U subrack. **Example:** where 160mm PCBs are required in a frame where the rear extrusions are set for 220mm deep PCBs.

Rear dividers can be supplied as listed below (as a 6U kit), or can be configured by using 3U and 6U dividers together with rear tie bars and tapped strips which are available separately.

Contents of kit

Description	Qty.	Material/finish
36HP Top and bottom rear tie bars	2	Aluminium alloy extrusion BS 14746063T6, conductive clear chromate
36HP Mid-rear tie bar	1	Aluminium alloy extrusion BS 14746063T6, conductive clear chromate
6U Rear divider plate	1	1,6mm Aluminium alloy BS1470NS4 1/2H, conductive clear chromate
Assembly screws	Kit	

Ordering information

Description	Qty.	Order code
6U x 36HP Right hand divider kit	1	950-203688

REAR DIVIDER PLATES

Rear divider plates are available in both 3U and 6U heights. Rear tie bars, tapped strips, fixing screws etc. should be ordered separately to suit the required width of the divided area. Should non-standard divider widths be required the tie bars can easily be cut to suit (see illustration opposite).

Contents of kit

Description	Qty	Material/Finish
Divider plate	1	1,6mm Aluminium alloy conductive clear chromate
Fixing screws		

Ordering information

Description	Qty.	Order code
3U Divider plate	1	950-202623
6U Divider plate	1	950-202624

Note: when a 6U divider plate is used a short piece of tapped strip should be fitted into the mid rear tie bar.

NON-STANDARD WIDTH REAR DIVIDER EXTRUSIONS

In order to produce other widths of divider kits, a larger, standard width should be modified as shown (see illustration at right). Please note that the tie bar lengths differ depending upon whether the required divider area is left or right handed.

Order separately

Product	Page
Rear top/bottom backplane tie bars	31
Mid rear tie bars	31
Rear DIN 41612 connector tie bars	32
DIN 41612 conversions frames/extrusions	34
Backplane insulation/conductive spacers	34
Tapped strips	34
Fixing screws	48

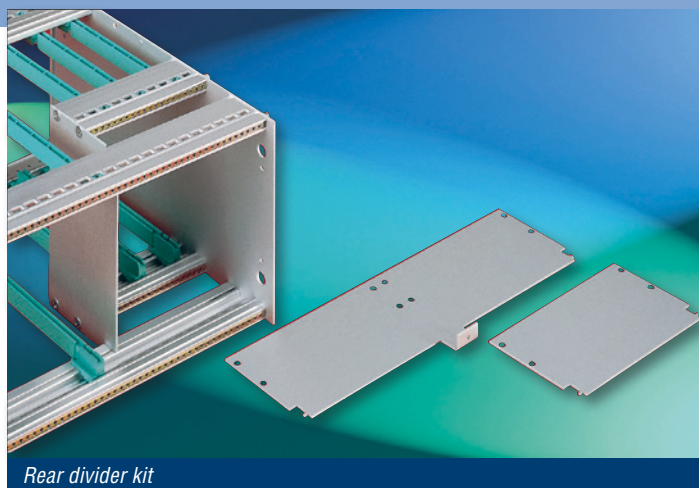

Rear divider kit

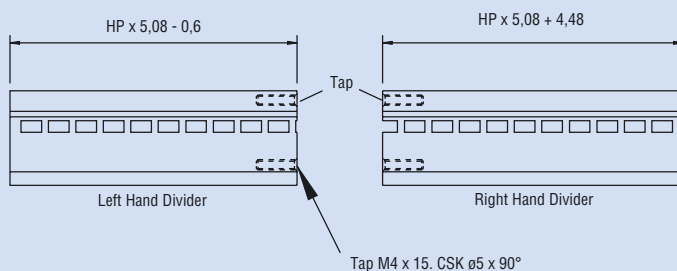

Rear divider tie bar

TOP AND BASE COVER KITS

This range of top and base covers are suitable for fitting to both Standard and Universal KM6-II subracks .

Two depths are available for protecting the guide area of 160mm or 220mm boards. The covers are available in ventilated or unventilated versions and can be fitted after the subrack has been assembled. A slot in the rear tie bar captures the cover and plastic clips secure it to the front. The cover can thus be easily removed for access.

Contents of kit

Item/Description	Qty.	Material/Finish
Covers	2	0,9mm aluminium alloy BS14705251(NS4H6) conductive clear chromate
Cover retaining clips	8	Grey ABS

Ordering information

Description: Top and base cover kits

Type	Card depth	Qty.	Order code
Ventilated	160mm	2	950-202625
	220mm	2	950-202626
Unventilated	160mm	2	950-221913
	220mm	2	950-221914

OTHER CONFIGURATIONS

It is possible on Universal Subracks to use the EMC covers as ordinary



Top/base covers

REAR COVER KITS

Suitable for both Standard and Universal KM6-II Subracks, these are available in heights of 3U and 6U and are assembled to the endplates. All KM6-II endplates are pre-punched to accept these covers.

The rear cover adds 41mm to the overall depth of a subrack.

Contents of kit

Description	Qty.	Material/Finish
Cover	1	0,9mm aluminium alloy BS14705251(NS4H6) conductive clear chromate
All fixings		

Ordering information

Description: Rear cover kit	Qty.	Order code
3U rear cover	1	950-202641
6U rear cover	1	950-202642



Rear cover kit

HORIZONTAL MOUNTING MODULES

This unit, which fits into a subrack like a 3U module, is actually a 6U x 20HP subrack on its side. This module permits the use of normal guides, front panels, plug-in units etc. and solves the problem of housing double Eurocards, i.e. 6U cards, in a 3U subrack, a situation which is frequently associated with modern bus systems.

The horizontal mounting module offers a number of additional advantages. It can be sub-assembled separately from the main subrack, and it offers "chimney" cooling between the end plates.

Contents of kit

Description	Qty.	Material/Finish
End plates	2	2,0mm Al chromate
Front tie bars	2	BS 1474 HE 9 TE extrusion conductive clear chromate
Rear backplane tie bars	3	BS 1474 HE 9 TE extrusion conductive clear chromate
Insulating strips	4	PVC grey UL 94.VO
Tapped strips	6	Mild steel zinc and passivate
Trim panels	2	1,0mm Al etch and clear anodise
Infill panel	1	2,5mm Al etch and clear anodise
Insulating sheet	1	Mylar 240
All fixings		

Notes

- A. The unit can be supported over its depth by fitting one or two plug-in guides to the main subrack directly under the horizontal module.
- B. In order to maintain correct connector geometry it is necessary to fit a spacer, either conductive or insulating, between the rear backplane mounting extrusions and the motherboard/backplane.

Ordering information

Description: Horizontal mounting module

Type	Depth	Qty.	Order code
Horizontal module	160mm	1	950-202971
	220mm	1	950-202972
PCB guide	160mm	Pk10	950-232662
	220mm	Pk10	950-232663

KM6-II HORIZONTAL MOUNTING MODULES – ACCESSORIES

Order separately

Product	Page
Backplane insulation/conductive spacers	34
DIN 41612 Connector mounting frame	34
DIN 41612 Connector mounting extrusions	34
PCB or Module guides (1 or 3 part types)	35
PCB Grounding clips	36
Positive guide retention – tapped strips	36
PCB Retainers and PCB guide nose	37
PCB Ejectors and card handles	38

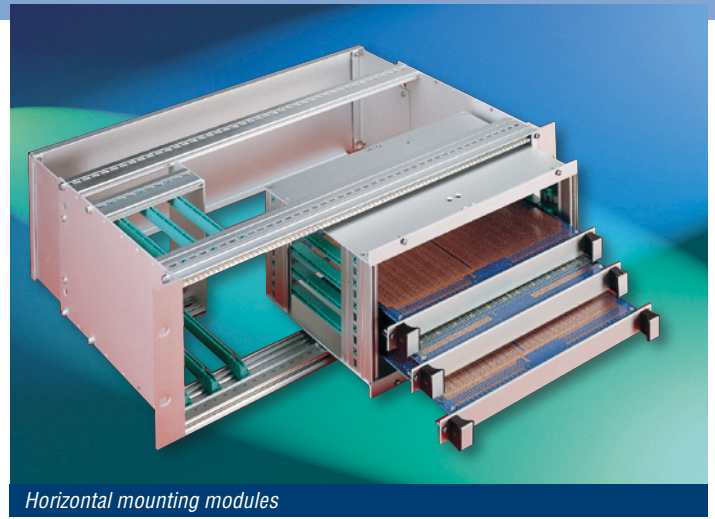

Horizontal mounting modules

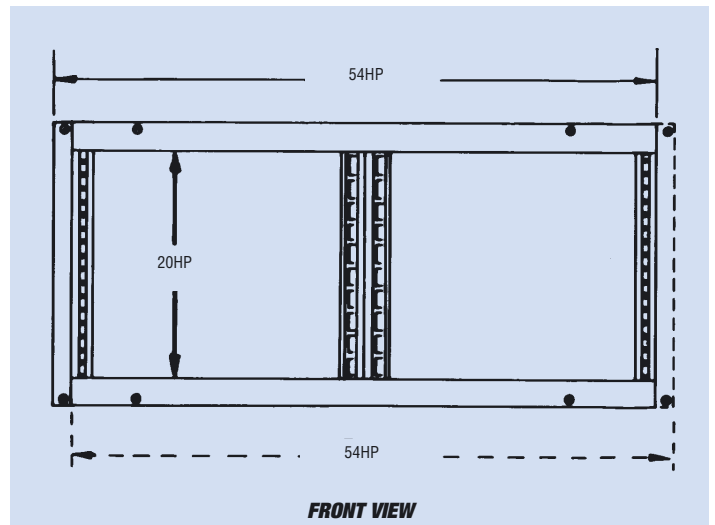

PERIPHERAL MOUNTING ADAPTERS (PMA)

Verotec's peripheral mounting assemblies (PMAs) are designed to comply with industry standard IEC60297 (for standard eurocard applications) and IEEE1101.10, for use in VME64 Extensions and CompactPCI systems. Standard eurocard types use a 3mm anodised aluminium front panel with fixed handles whilst VME64x & CPCI types have chromated (conductive) front panels with RFI gasket and fixed handles. Both are supplied with fixing hardware.

Three types are available; the first is for vertically mounting a single standard 5.25", front accessible peripheral such as a CD / DVD drive. The second is for mounting one standard 3.5", front accessible peripheral (such as a floppy disk) and one standard 3.5", embedded peripheral (such as a hard disk drive). The third is for mounting a single 2.5" embedded hard disk drive.

ORDERING INFORMATION

Standard IEC60297

Module Size	Drive Type	F/Panel Cutout	Ordercode
6U x 12HP	1 x 5.25"	1 @ 41 x 147mm	950-4001256
6U x 8HP	2 x 3.5"	1 @ 25 x 102mm	950-4001257
3U x 4HP	1 x 2.5"	N/A	950-4002633

Shielded IEEE1101.10

Module Size	Drive Type	F/Panel Cutout	Ordercode
6U x 12HP	1 x 5.25"	1 @ 41 x 147mm	950-4001327
6U x 8HP	2 x 3.5"	1 @ 25 x 102mm	950-4001328
3U x 4HP	1 x 2.5"	N/A	950-4005469



5.25" and 2.5" peripheral mounting assemblies

AIR BAFFLE CARDS

The air baffle card is designed to be used in vacant system slots to both close the front panel area and block airflow. In doing so, cooling air is diverted to active cards, thus maintaining the correct system airflow profile.

The air baffle card is available with or without handles, in standard 3U and 6U Eurocard heights, depths of 160mm and 220mm and is 4HP (one slot) wide. Customers also have the choice of either an unshielded (IEC60297) version or a shielded (IEEE 1101.10) version.

ORDERING INFORMATION

Standard (IEC 60297) versions:

Description	Ordercode
3U x 160mm, with handles	950-4001329
3U x 160mm, without handles	950-4001330
3U x 220mm, with handles	950-4001331
3U x 220mm, without handles	950-4001332
6U x 160mm, with handles	950-4001333
6U x 160mm, without handles	950-4001334
6U x 220mm, with handles	950-4001335
6U x 220mm, without handles	950-4001336

Shielded (IEEE 1101.10) versions:

Description	Ordercode
3U x 160mm, with handles	950-4001337
3U x 160mm, without handles	950-4001338
3U x 220mm, with handles	950-4001339
3U x 220mm, without handles	950-4001340
6U x 160mm, with handles	950-4001341
6U x 160mm, without handles	950-4001342
6U x 220mm, with handles	950-4001343
6U x 220mm, without handles	950-4001344



Standard 6U 4HP 160mm air baffle card with handles

SUBRACK HANDLES

These handles are identical to those supplied in the KM6-II subrack kit as featured on pages 20 and 22, and offered here as accessories to the KM6 range.

Features

- Stylish modern appearance
- Comfortable hand grip
- Range of sizes

Compatible, pre-drilled 3U and 6U end plate angles are shown on page 29, but other sizes of end plate angle can easily be modified to suit application requirements.

Contents of kit

Description	Qty.	Material/Finish
Handle	1	Aluminium alloy E6, Etch and clear anodised

Ordering information

Height	A	B	Qty.	Order code
3U	116,3mm	108,3mm	1	50-10117
4U	160,8mm	152,8mm	1	50-10116
6U	249,7mm	241,7mm	1	50-10118
Screw M3, 5 x 10 countersunk head			Pk 10	173-10036

Order separately

Description	Page
Fixing screws	Code as above

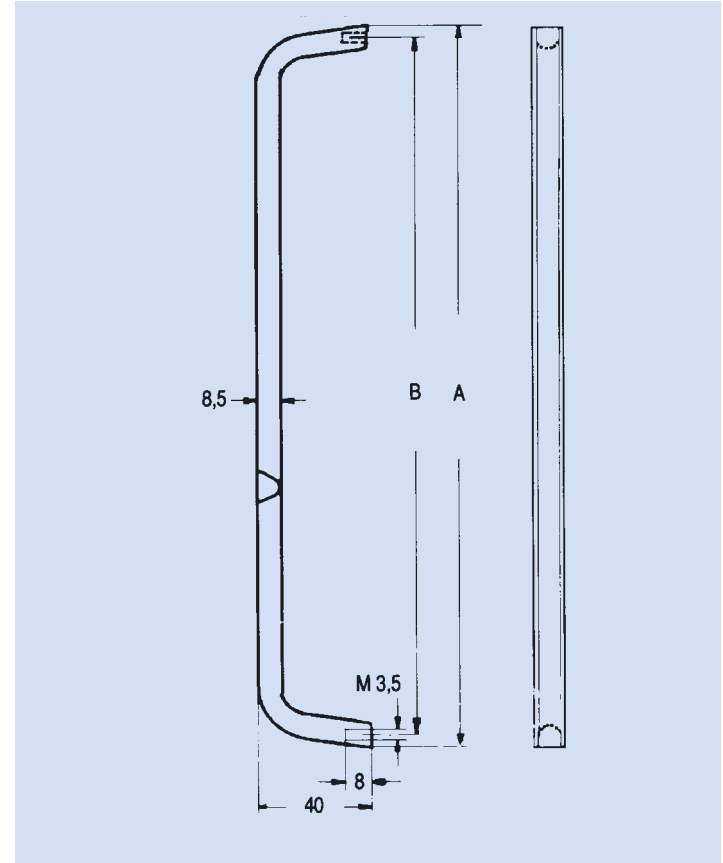
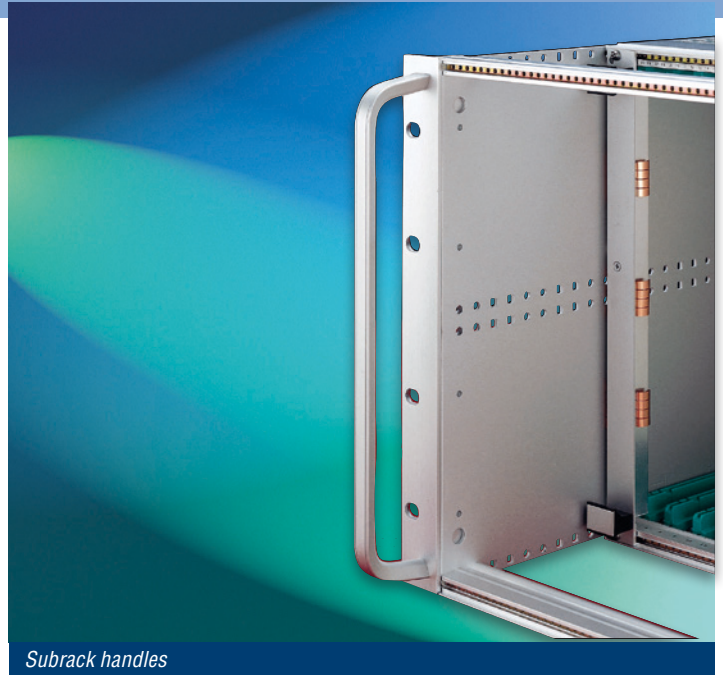

REAR HINGED CONNECTOR MOUNTING PANEL

This hinged rear panel provides a means of mounting plugs and sockets, and extends the depth of the subrack by 76,2mm. This extension in depth gives sufficient additional space between the backplane and the rear panel to allow wiring to the connectors.

Contents of kit

Description	Qty.	Material/Finish
Side plates	2	1,6mm aluminium, conductive clear chromate
Rear panel	1	1,6mm aluminium, conductive clear chromate
All fixings		

Ordering information

Description: Rear hinged panel

Height	Width	Order Code

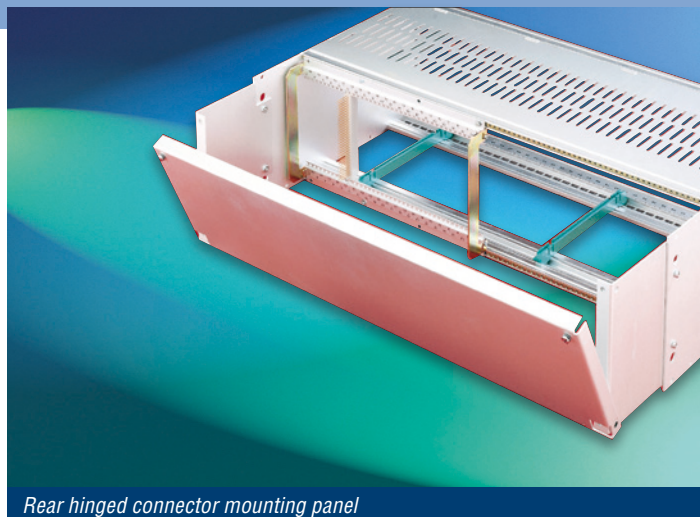

Rear hinged connector mounting panel

FRAMING KIT

For applications such as the addition of an overall rear panel or where a subrack is reverse mounted on a wall or electrical panel, for instance, this kit provides an aesthetically pleasing frame.

It is available in three heights, and a standard width of 84HP.

Contents of kit

Description	Qty.	Material/Finish
Closing angles	2	BS 1474 HE9TF extrusions conductive clear chromate
Plain extrusions	2	BS 1474 HE9TF extrusions conductive clear chromate
Tapped strips	2	MS zinc and colour passivated
Fixing screws	8	

Ordering information

Description: Framing kit

Dimensions	Qty.	Order code
3U x 84HP	1	950-222331
6U x 84HP	1	950-222332
9U x 84HP	1	950-222333

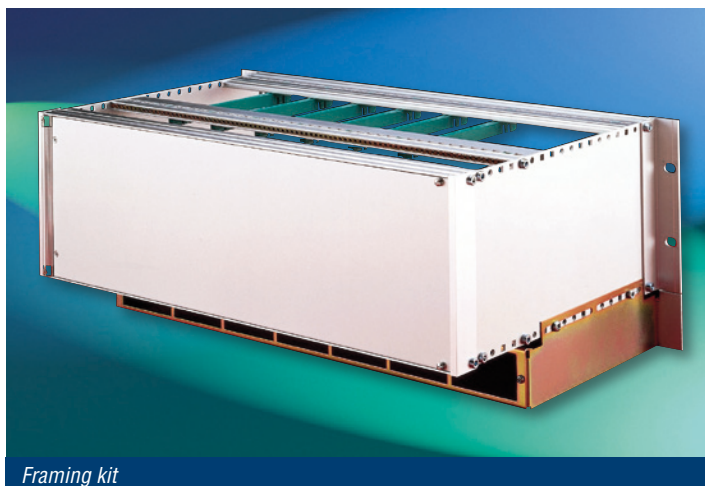

Framing kit

CONNECTOR PROTECTION PLATES

Suitable for 3U/6U subracks, designed to protect connectors and wiring against damage. The plates bolt onto pre-drilled positions on the subrack endplates and add 30mm to the overall depth of the subrack.

Contents of kit

Description	Qty.	Material/Finish
Plates	2	2,5mm aluminium BS 1470 NS4 1/2H conductive clear chromate
All fixings		

Ordering information

Description	Qty.	Order Code
Connector protection plate	2	950-202751

Note: It is recommended that two kits are used on 6U frames.



Connector protection plates

KM6-II Subracks: Accessories

KM6-II CHASSIS SYSTEM

The chassis system offers a method of mounting simple plates into subracks. They can be used for carrying additional components such as power supplies, or for securing wiring etc.

The components of this system are designed for maximum versatility.

The extrusion has an M4 section which will accept hex nuts or screws directly and a section which will accept a KM6-II tapped strip or M2,5 hex nuts and screws. The extrusion is tapped M4 for fixing and our standard subrack kits have additional holes to provide convenient mounting centres.

Contents of kit

Description	Qty.	Material/Finish
Extrusions	1	aluminium alloy BS1474 6063T6, conductive clear chromate

Ordering information

Description	Unit	Order code
Chassis extrusion, 42HP	each	956-242701 M
Chassis extrusion, 60HP	each	956-242702 M
Chassis extrusion, 84HP	each	956-242703
Screws M2,5 x 8 hex head	Pk 100	956-243262
Screws M4 x 8 hex head	Pk 100	956-243263
M2,5 hex nuts	Pk 100	27-1319
M4 hex nuts	Pk 100	956-243264
Extrusion fixing screw M4 x 12 pan posi	Pk 100	956-243261

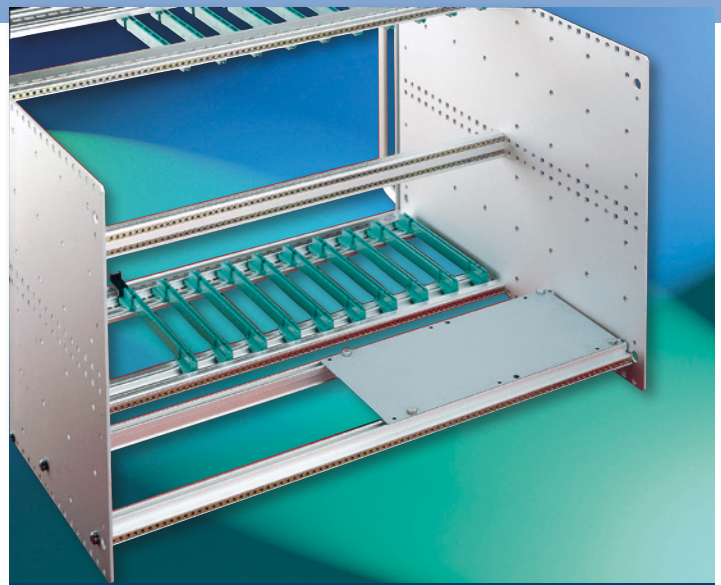

KM6-II Chassis system

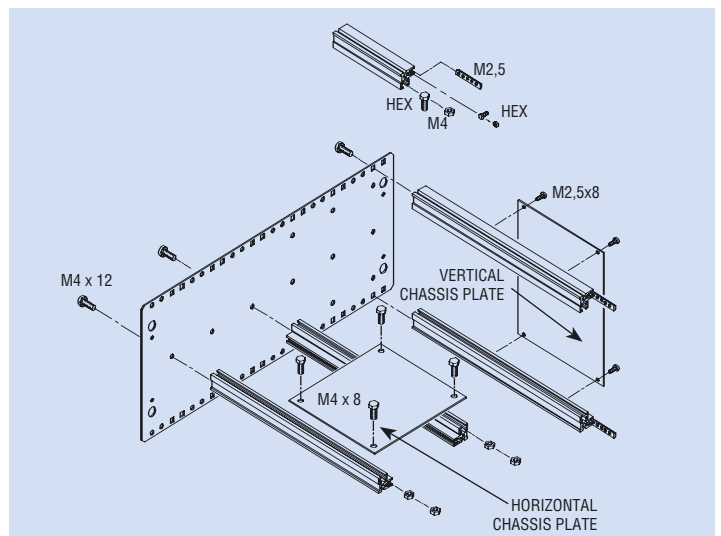

KM6-II fixings

SUBRACK FIXINGS

Ordering information

Key	Function	Type	Qty.	Order code
1	End plate to tie bar extrusions	M4 x 25 skt cap	pk 100	950-202734
2	Connector to rear tie bar	M2,5 x 6mm	pk 100	173-12530
3	Backplane to backplane extrusion	M2,5 x 5mm	pk 100	173-202579
4	Guides to front tie bar	M2,5 x 6	pk 100	173-12530
5	Backplane to backplane extrusion	M2,5 x 8	pk 100	41-227257

